

News from Rohde & Schwarz

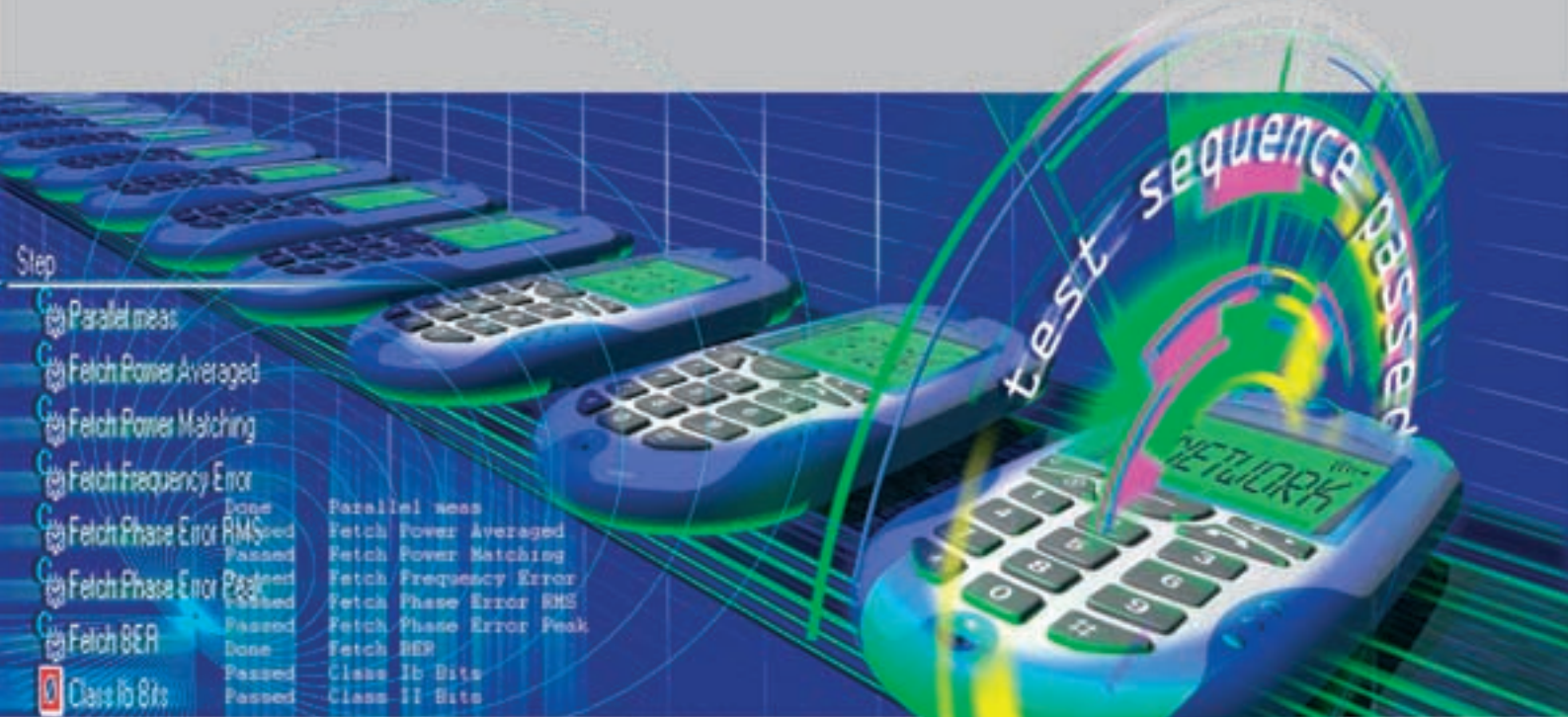

Cellular phone production test platform – compact, flexible and ready to go

Multichannel video quality monitoring in digital TV broadcasting networks

DF antennas from HF to UHF, stationary and mobile

2000/IV

169



ROHDE & SCHWARZ

By the year 2004, the annual requirement for mobile phones will have risen beyond a billion – a challenge for producers of phones and test equipment alike. Cellular Phone Production Test Platform TS7100 can help meet this challenge: it handles all common mobile-radio standards worldwide and will be upgradable to support third-generation mobile radio. It is designed for easy interfacing with customer-specific manufacturing processes (page 4)



Photo 43644

MOBILE RADIO

Test systems

Cellular Phone Production Test Platform TS7100
Compact, flexible and ready to go for mass production..... 4

Protocol testers

Protocol Tester PTW60 for Bluetooth™ applications
Comprehensive protocol tests to Bluetooth™ qualification program..... 8

Test methods

Universal Radio Communication Tester CMU 200
Measuring bit error rate on GSM mobiles 11

Signal Generator SMIQ
Simulating channel models for 3GPP fading tests 14

Signal Generator SMIQ
TETRA T1 test signals to standard..... 16

RF MEASUREMENTS

RF signal generators

Signal Generators SML02 / 03
Economy class extended to 3.3 GHz 18

Test signals

I/Q Modulation Generator AMIQ / Signal Generator SMIQ
HiperLAN/2 signals with OFDM Simulation Software WinIQOFDM..... 21

Photo 43471/2



Precise tester for Bluetooth™ qualification and excellent measurement tool for the development of components to this standard: Protocol Tester PTW60

Photo 43412/6



Economy class now also up to 3.3 GHz: Signal Generator SML03



Photo 43 318/7

EMMY award for the measurement principle of Digital Video Quality Analyzer DVQ. DVQM is the space-saving multichannel version of DVQ



Photo 43 598/2

Different transmitter output power ratings can be implemented thanks to the new cascaded power combiners (page 24)

BROADCASTING

TV transmitters

Power combiners for UHF Transmitters NH / NV 7000

Different transmitter power ratings made easy 24

◀ Video quality monitoring

Multichannel Video Quality Analyzer DVQM

Multichannel monitoring in digital TV broadcasting networks 26

Refresher topics

Measurements on MPEG2 and DVB-T signals (2) 29

RADIOMONITORING

DF antennas

DF antennas for every purpose – From HF to UHF, stationary and mobile 33

IT SECURITY

Crypto products

SITLink – Secure and confidential communication on leased lines 36

FOCUS

Technical documentation

HTML online help –

Expert knowledge available at a mouse click 42

MISCELLANEOUS

CD-ROM tip: T&M Dream Team for Digital TV 38

Test tip: Measuring noise figure on amplifiers in pulsed mode 39

Test tip: Accurately measuring drift on Bluetooth™ transmitter modules 40

Publications 44

In the press 45

Newsgrams 45

Imprint Published by Rohde & Schwarz GmbH & Co. KG · Mühlendorfstrasse 15 · 81671 München

Support Center: Tel. (+49) 01805 124242 · E-mail: customersupport@rohde-schwarz.com

Fax (+4989) 41 29-137 77 Editor and layout: Ludwig Drexler, Redaktion – Technik (German)

English translation: Dept. HW-UK7 · Photos: Stefan Huber · Circulation (German, English and French) 90 000

approx. 5 times a year · ISSN 0028-9108 · Supply free of charge through your nearest Rohde & Schwarz

representative · Printed in Germany by peschke druck, München Reproduction of extracts permitted if

source is stated and copy sent to Rohde & Schwarz München.

Cellular Phone Production Test Platform TS 7100

Compact, flexible and ready to go for mass production

TS7100 is a compact, ready-to-go test platform for use in the mass production of mobile phones, i.e. for PCB tests, RF adjustments and final tests. It can handle all common mobile-radio standards worldwide and is planned to be upgraded to support third-generation mobile radio (3G). In its design, the focus was on easy interfacing with customer-specific manufacturing processes besides maximum throughput. Worldwide customer support is guaranteed by regional Rohde & Schwarz integration centers.

The challenges: time to market and time to volume

More than eight years of digital mobile radio, and there is still no end of the boom in sight. By the year 2004, the annual requirement for mobile phones will have risen beyond a billion – a challenge for producers of phones and test equipment alike. Rohde & Schwarz can look back on wide-ranging, international experience in project handling, having supplied more than 1000 production test systems for mobile phones. This guarantees that the standardized production

test platform presented here will enable users to overcome time-to-market and time-to-volume problems.

TS 7100 is based on a combination of several easy-to-handle and also otherwise deployable standard hardware and software components, which are complemented by ready software libraries and test sequences. This ready-to-go solution as well as the high versatility and easy interfacing of the system allow its fast and easy configuration for a given UUT and different stages of the production process (FIG 1).

FIG 2 TS 7100 in low-profile rack configuration



Photo 43 443/6

TS 7100 in production

The production test platform is made up of the following standard components:

- Multistandard Universal Radio Communication Tester CMU 200
- Test System Versatile Platform TSVP
- Generic test software library (GTSL)
 - TestStand test sequence control
 - UUT power supply

Just 80 cm high in the low-profile rack configuration (FIGs 2 and 3), TS 7100 can be set up as a two-channel system for the simultaneous testing of two mobile phones. In this case, the system components are fitted on both sides, and the rack can even be placed under the conveyor belt of a production line. Alternatively, a 130 cm conventional, high-profile rack with components fitted only on one side is available (FIG 4).



ETSI MEMBER

...making the right connections.

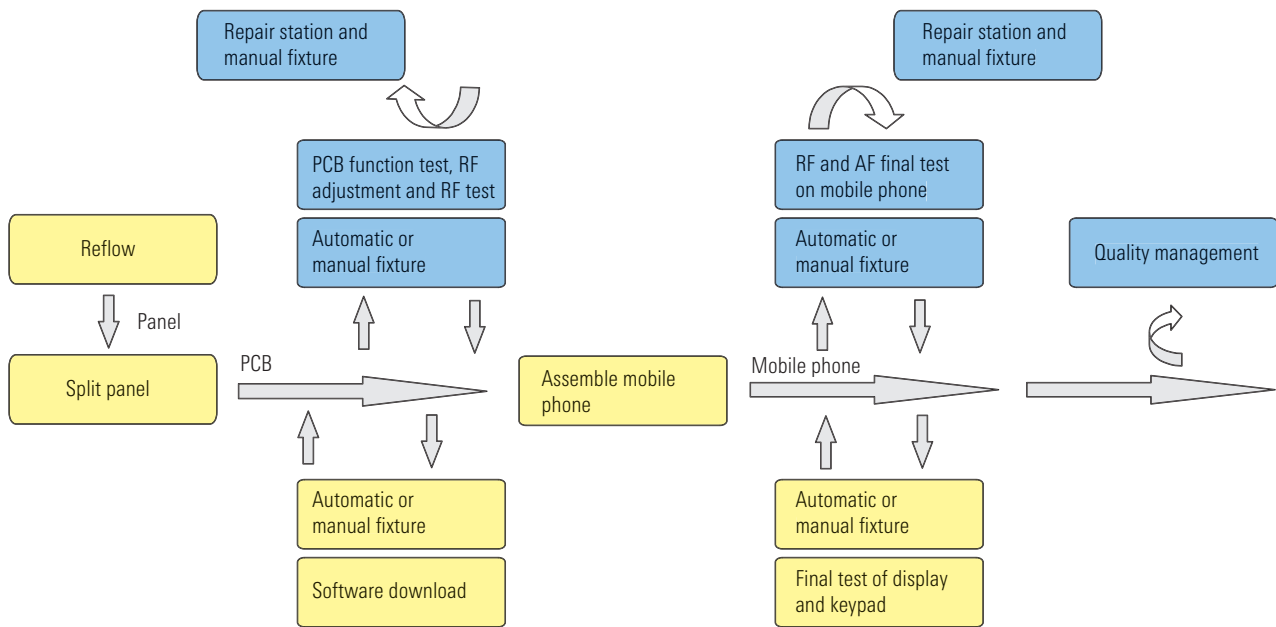

FIG 1 Typical use in mobile-phone production line (blue: TS 7100 functions)

Makes for high yield: Universal Radio Communication Tester CMU200

Compared with conventional testers, CMU200[*] is up to ten times faster and far more accurate, plus it offers parallel measurement capability. It is of modular design and can be extended for future standards. So, hardware or software options can be added at any time to make CMU 200 a multistandard tester. This presently applies to all common standards of the second generation such as GSM, CDMA (IS-95), AMPS, TDMA (IS-136) as well as GPRS and Bluetooth™ and of course the upcoming EDGE and 3G (W-CDMA and CDMA2000). In TS 7100, CMU 200 performs all acoustic and RF tests – with and without signaling. Of decisive importance, especially in production environments, are its compact size (4 HU), low power consumption, in-depth selftest capability and high reproducibility of results.

Test System Versatile Platform TSVP

Test System Versatile Platform TSVP (FIG 5) has a maximum configuration of 31 slots for the system controller, switching and test modules as well as digital channels for driving the fixture. The unique wiring concept of TSVP makes it possible to route and switch all signals of the various test and stimulus modules entirely within TSVP. So all signals can be tapped directly at the fixture interface, which allows simpler fixture and interface design.

The PXI system architecture (PCI eXtension for Instrumentation), now an industry standard, was developed from CompactPCI especially for industrial T&M applications. It ensures a maximum of flexibility and compactness. A large number of very different PXI modules are already available on the market. CompactPCI boards can also be used.

Like the VXI bus, the PXI bus has a variety of trigger functions and internal bus lines to transfer signals from one module to the other. But it is more compact, simpler to extend and, with data throughput of up to 132 Mbyte/s, more than three times faster.

Photo 43443/8



FIG 3 Low-profile rack configuration, components on rear



Photo 43443/10

ported too, i. e. hardware components are shared by several threads, thus simplifying parallel testing of several mobiles for example.

The software includes ready-to-run test cases for all major measurements and all common mobile-radio standards. Tests for the various functional blocks of mobiles, such as audio and acoustic, RF and signalling, are included. The test cases are implemented as DLLs (dynamic link libraries) and can be combined into test sequences and parameterized in a menu-controlled dialog. The limit values for the results are compiled in an ASCII file and automatically assigned to the corresponding test steps. Limit values can thus be modified or adapted fast and easily using a standard editor. Depending on the required scope, different test cases from the library can be combined into functional or final tests.

TestStand test sequence control

The TestStand software from National Instruments is used for test sequence control. It joins the individual steps to form an executable program, controls user administration as well as the execution of several test sequences in multithreading or parallel mode. A so-called station model adds all other functions important for the manufacturing process such as collection and storage of results in databases, report generation, etc. Plus, TestStand offers various call interfaces (e. g. ActivX, DLL, C) and functions for executing and debugging test sequences. The integrated sequence editor makes it easy to generate a sequence by joining various tests and modify it any time (FIG 6). The data measured during a test run are collected and can be used for automatic generation of reports or stored in a database for post-evaluation.

FIG 4
TS7100 in 130 cm high-profile configuration

FIG 5

All test and stimulus modules are interconnected in TSVP. Various configurations are possible



Photo 43432/7

► Comprehensive software

With the modular TS 7100 software, the user can create test programs fast and easily without in-depth programming knowledge. It comprises the TestStand test sequence control and a comprehensive GTSL (generic test software library) for mobile radios of different standards.

A resource manager ensures that test sequences are executed independently of the system configuration, i. e. with different hardware. Resource locking is sup-



Photo 43633/5

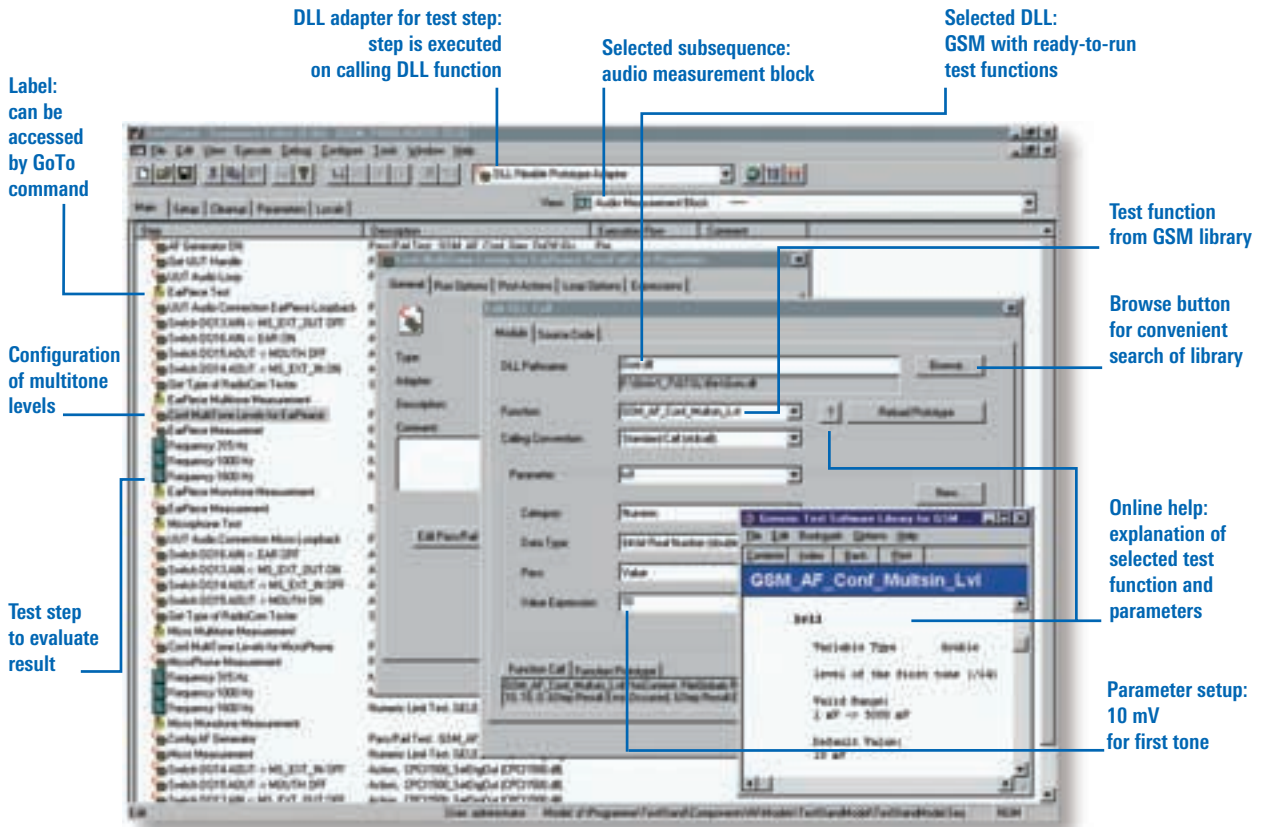

FIG 6 Test sequence editor for fast and easy generation of test sequences

On request: all-in-one solutions from Rohde & Schwarz

Rohde & Schwarz has a wealth of expertise in planning and implementing turn-key T&M systems for applications in the telecom industry. For mobile phones, the company develops ready-to-run test programs and custom test cases, and supplies fixtures for manual use or integration into automatic production lines. Experienced engineers help the user find

the test strategy and system configuration optimal for his particular application.

Rohde & Schwarz regional integration centers provide customer support worldwide. They assist the users in selecting and configuring a system that best suits their application and also integrate the system into the production line. Service and maintenance after installation as well as training of operator personnel are also available. Maintenance con-

tracts can be tailored to a customer's special requirements.

Rohde & Schwarz is the competent partner when your priorities are minimizing test costs, full test capability and extremely short time to volume.

Manfred Gruber; Georg Steinhilber

REFERENCES

[*] Universal Radio Communication Tester CMU 200: On the fast lane into the mobile radio future. News from Rohde & Schwarz (1999) No. 165, pp 4-7

Reader service card 169/01

Protocol Tester PTW60 for Bluetooth applications

Comprehensive protocol tests to Bluetooth™ qualification program

One of the prerequisites for acceptance of Bluetooth technology* by the user and thus successful and widespread application is full interoperability of the different implementations. To ensure this interoperability, the special interest group (SIG) has defined a qualification program [*] that every product must pass to go to market under the Bluetooth label.



Photo 43471/2

FIG 1 Protocol Tester PTW60 is both a tester for Bluetooth qualification and an excellent measurement tool for the development of components to this standard

Tester for all cases

PTW60 performs protocol tests according to the SIG qualification program. In addition to RF measurements, this program also prescribes signalling tests of the following layers and profiles:

- Bluetooth layer baseband (BB)
- Link manager (LM)
- Logical link control and adaptation protocol (L2CAP)
- Service discovery application profile (SDAP)
- Serial port profile (SPP)
- Generic access profile (GAP)

All protocol tests are defined with the description language TTCN (tree and tabular combined notation). Protocol Tester PTW60 (FIG 1) automatically converts the TTCN test cases into executable

code. FIG 2 shows the sequence of this procedure. In ".mp" format, the test suites are copied into PTW60 and there the TTCN compiler (part of the basic unit) first translates them into ANSI-C code. After compiling this code, the linker generates executable test programs from the object files obtained and from the simulator library of the associated test suite (options).

* Bluetooth is a registered trademark of Telefonaktiebolaget LM Ericsson Sweden and is licensed to Rohde & Schwarz.

Convenient test case manager

The test programs (test cases) are then available in the PTW60 test case manager (FIG 3), which helps to combine and perform any sequences and repetitions of the test cases. The test case generates sequence recordings based strictly on the executed lines of the *TTCN* test case; this allows simple correlation with the easily readable, tabulated *TTCN* code. After performing protocol tests on a Bluetooth product, the test case manager generates at a keystroke a test report in *HTML* format. This can be analyzed or printed either with the supplied browser or via *HTTP* Internet protocol with any browser in the network.

In addition, a so-called session is generated for each test case, an archive on PTW60 that stores all data generated. This ensures their later availability and reproducibility, either for error analysis, for test reports when qualifying a product, or simply for comparison when repeating a test.



FIG 3
Any sequences and repetitions of test cases can be combined in the test case manager

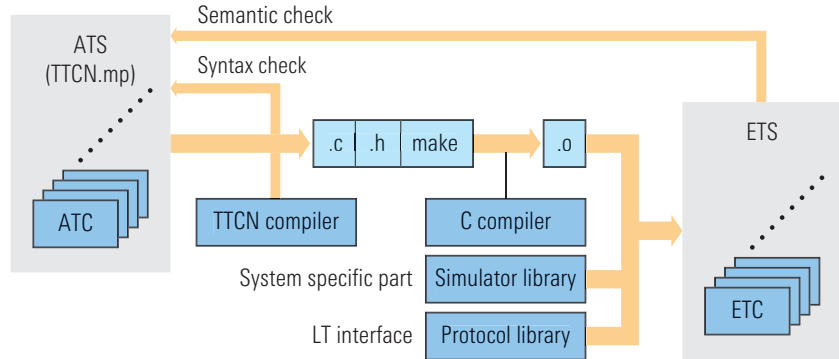

FIG 2 Automatic generation of executable *TTCN* test cases (ETCs) from *TTCN* code in PTW60

Helpful service providers

During operation, the *TTCN* test cases use services provided in PTW60. The link controller implemented in PTW60 is one of the providers whose services are utilized by Bluetooth layers *LM* and *L2CAP* (FIG 4). By deactivating one or more layers, *TTCN* test cases can replace the particular layer and access the support of a service provider. In addition to Bluetooth layer *LC*, the reference implementations of Bluetooth layers *LM* and *L2CAP* are also available in PTW60, which in turn provide new services for protocol test cases.

PTW60 at a glance

Major applications

- Protocol tests for the development of basic layers and profiles
- Protocol qualification (compliance tests) of layers and profiles by performing *TTCN* test cases
- Reference implementation of baseband, *LM* and *L2CAP* in master and slave modes
- Implementation of test mode signaling (master)

Major functions

- Simulation of one (optionally two) Bluetooth Piconets (baseband, *LM* and *L2CAP*)
- Automatic generation of executable test cases (*ETC*) according to *SIG* abstract test suites (*ATS*) via *TTCN* and C compiler
- Platform for executing *SIG* protocol/profile tests for baseband, *LM*, *L2CAP*, *GAP*, *SPP* and *SDAP*
- Open programming interface with numerous options to define scenarios
- Message editor
- Link to external layers via TCP/IP
- Many features to analyze messages sent and received

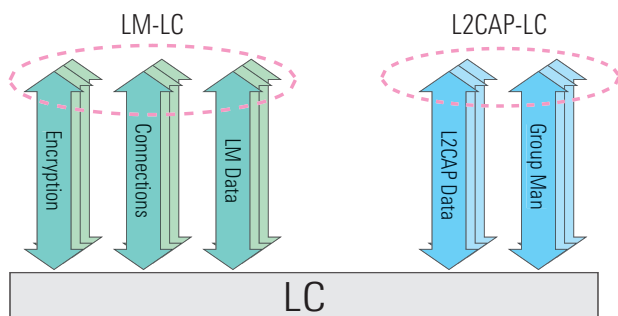

FIG 4
Bluetooth layer *LC*
provides services for
protocol test cases

Powerful tools for data analysis

The large amount of data between Bluetooth layers that is stored during the protocol tests requires powerful tools for fast analysis. *PCO* tools are available in PTW60 to interpret both received and transmitted data. Not only the bit stream received or transmitted can be displayed but also bit-by-bit interpretation to Bluetooth standard. Another helpful function is the generation of message sequence charts (*MSC*) in PTW60. *MSCs* are the chronological compilation of all primitives sent and received that – distributed across all Bluetooth layers – can be assigned to an event.

Protocol Tester PTW60 features convenient online help that explains at a keystroke the complex functions on the screen and virtually does away with the manual (page 42).

Peter Riedel; Ralf Wenninger

► User-specific test cases possible

Apart from the possibility to perform the protocol tests prescribed for Bluetooth qualification, PTW60 also offers a variety of applications in the development of Bluetooth components. Besides the *TTCN* test cases defined by *SIG*, users can formulate their own test cases in this description language and make some perhaps necessary extensions to the simulator libraries.

The implementation of test scripts in C programming language is also possible. To make this easier, C libraries are offered as programming interfaces (e.g. the protocol library in FIG 2). For instance, to create protocol primitives, libraries *ASP.lib* and *PDU.lib* are available, through which the entire implemented Bluetooth protocol can be addressed. Another library allows user-friendly, graphical operation of the test scripts.

Abbreviations

<i>ATC</i>	Abstract test case	<i>LC</i>	Link controller
<i>ATS</i>	Abstract test suite	<i>LM</i>	Link manager
<i>BB</i>	Layer baseband	<i>MSC</i>	Message sequence chart
<i>ETC</i>	Executable test case	<i>PCO</i>	Point of control and observation
<i>ETS</i>	Executable test suite	<i>SDAP</i>	Service discovery application profile
<i>GAP</i>	Generic access profile	<i>SIG</i>	Special interest group
<i>HTTP</i>	Hypertext transfer protocol	<i>SPP</i>	Serial port profile
<i>HTML</i>	Hypertext markup language	<i>TTCN</i>	Tree and tabular combined notation
<i>L2CAP</i>	Logical link control and adaptation protocol		

REFERENCES

[*] Specification of the Bluetooth System, Volume 1 Core, v.1.0 B, December 1999

[Reader service card 169/02](#)

Universal Radio Communication Tester CMU200

Measuring bit error rate on GSM mobiles

The test modes defined by GSM standardization committees prescribe how to measure the receiver characteristics of GSM mobile phones. This is the kind of application that CMU200 [1] with its advanced concept excels in.

BER – a measure of receiver sensitivity

The transmitter characteristics of GSM mobiles are relatively simple to measure, since the physical effects can be checked directly on the tester. But when it comes to receiver characteristics, the physical effects appear in the tested device itself, so no direct measurement is possible. GSM standardization committees therefore defined test modes for measuring the receiver characteristics of GSM mobiles.

The major feature of a receiver is its sensitivity. In digital systems, this is determined through the bit error rate (BER). The receiver is fed a test signal with pseudo-random bit sequence and defined level, and the number of bit errors is measured at its output.

In development and conformance testing of GSM mobiles the receiver characteristics have to be tested under various aspects like fading, multipath reception or intermodulation. But in production it is sufficient to stimulate the receiver with a low-level GSM signal. Usually, either reference sensitivity or absolute receiver sensitivity is measured on GSM mobiles.

Reference or absolute sensitivity?

To check the reference sensitivity, a signal with defined level (e.g. -102 dBm or -104 dBm for GSM900) is applied to the receiver. If the measured BER is below the specified limit, the receiver is ok. To determine the absolute receiver sensitivity on the other hand, the level of

the test signal is varied until a defined BER is obtained.

Obviously, absolute receiver sensitivity takes more time to measure than reference sensitivity. So in production, where you are interested in maximum throughput, measurement of the reference sensitivity is naturally often preferred.

BER test modes

The basic principle of the BER test modes is simple: the radiocommunication tester sends a data stream to the mobile, which then sends it back to the tester (loop). The tester compares sent and received data streams to determine the number of bit errors (FIG 1).

Various test modes (loop types) are defined. With types A, B, D, E and F the tester generates a pseudo-random bit stream, which is channel-coded and applied via the RF interface to the receiver of the mobile. There the data stream passes through the channel decoder and – via channel coder, RF interface and channel decoder – is sent back to the tester. What precisely the mobile sends back depends on the type of loop. With loop B it returns exactly what it has received. With loop A, however, received voice frames with non-correctable class 1a errors are not returned but marked as erased frames. This is possible because GSM voice transmission is protected by bits so that bit errors can be corrected. Depending on their significance, the protection bits are divided into the following classes:

- Class 1a bits: very good protection
- Class 1b bits: little protection
- Class 2 bits: no protection

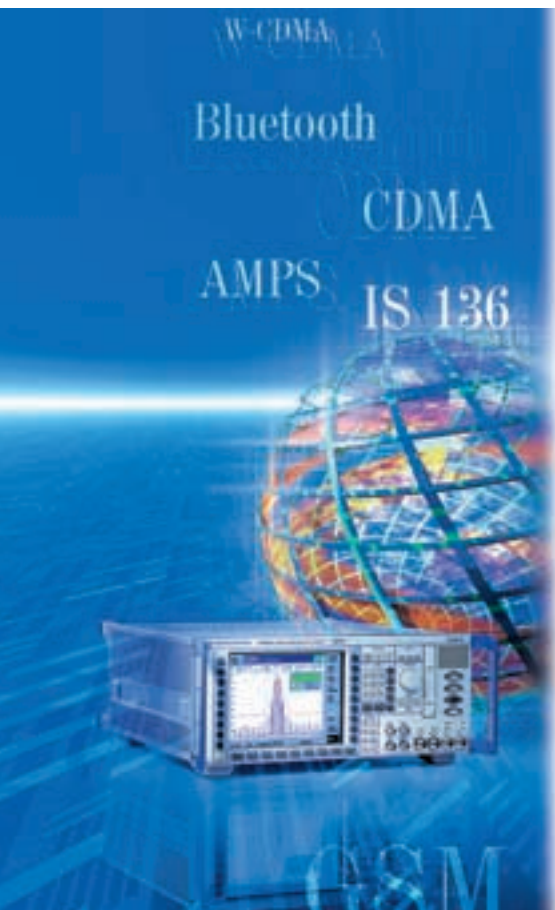

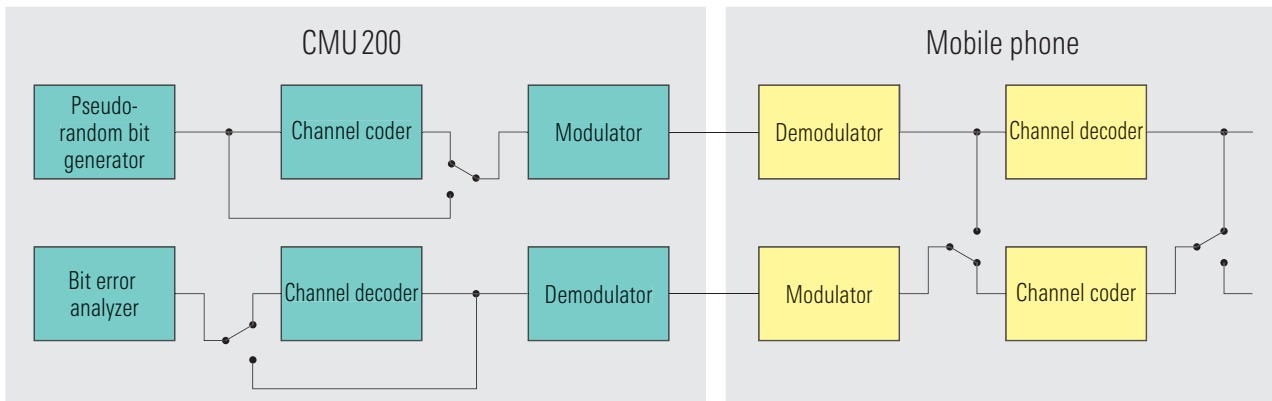

FIG 1 The GSM mobile can send the received data stream back to the tester via different loops: before (loop C) or after the channel decoder (loops A, B, D, E and F). The diagram shows switch positions for loops A, B, D, E and F. All switches are set opposite for loop type C

► In the case of erased frames the mobile sends back a voice frame consisting entirely of zeroes. On receiving such a voice frame, the tester increments the FER (frame error rate) counter. With this type of loop therefore only voice frames with a certain minimum quality are considered in the BER. This explains the singular effect occurring with this loop type, namely that with decreasing receive level the BER suddenly improves. The lower the level, the more erased frames occur. So only voice frames with the smallest number of bit errors will be considered in the BER measurement.

Loop types D, E and F are used for half-rate connections and are of minor significance in production. Like with loop type A, certain frames are not considered in the BER measurement (unreliable frames, erased SID frames and erased valid SID frames). Such frames are marked by zeroes.

The larger the numbers of mobile phones produced, the more important it becomes to cut testing times. This was the reason for introducing loop type C. The mobile sends back the received data stream without taking it through the channel decoder. The advantage here is that, for the same transmission period, about five times as many bits are avail-

able for determining bit errors. This type of loop is not supported by all mobile phones however.

Further loop types and test modes have meanwhile been defined for the new and upcoming mobiles that support HSCSD (high-speed circuit-switched data) and GPRS (general packet radio services).

Measuring GSM BER with CMU200

Outstanding convenience

The advanced concept of Universal Radio Communication Tester CMU200 excels not only in transmitter measurements (see [2] and [3]) but also in receiver measurements. BER measurement is coupled to a special transmitter level setting for instance. Using a high transmitter level it ensures reliable call setup with the mobile. As soon as the BER measurement is active, the tester automatically selects a low transmitter level and, after completing the measurement, returns to the high level.

Data stream transfer from CMU200 to the mobile is also very convenient for the user: during the BER measurement, CMU200 automatically selects a pseudo-

random bit sequence. And of course it opens and closes the test loops in the mobile automatically. All these features enable straightforward operation of the tester.

CMU200 also classifies the bits and provides limit values for each class (FIG 2).

Reference sensitivity

Ten test setups are available for fast and convenient checking of reference sensitivity. Different transmitter levels, test sequence lengths, BER limits and loop types can be preset. The setups can then be called up as test routines, avoiding tiresome reconfiguration between different BER measurements.

CMU200 also reduces test time for faulty mobiles by prematurely terminating the BER measurement if the required reference sensitivity cannot be achieved.

Absolute receiver sensitivity

For determining the absolute receiver sensitivity the tester provides an optimized routine that allows presetting of the desired averaging depth for BER measurement. During the ongoing measurement the sliding BER average is measured with the aid of this window. The user can at the same time directly vary the transmitter level by means of numeri-

cal entry or with the spinwheel. This is a fast and easy way to determine absolute receiver sensitivity. CMU200 is optimized for use in production, so it also supports loop type C, allowing a very significant reduction in testing time.

AGC test

For testing the AGC (automatic gain control) of a receiver, CMU200 provides different transmitter levels for the active timeslot and for the unused timeslots. The receiver in the mobile can thus be subjected to unfavourable conditions in the unused timeslots. Plus, it is possible to define a delay for AGC settling in the mobile.

Pseudo-random bit streams

The tester uses a choice of four true pseudo-random bit sequences for BER measurement. You will especially appreciate this feature if you have ever overlooked a faulty channel coder by using a fixed bit pattern, because a pseudo-random sequence is the only reliable means of detecting it.

For transmitter measurements the BER loop can also be kept closed outside BER measurement. This is a simple way of meeting the requirement for a mobile phone transmitter signal modulated with pseudo-random bits, as needed for spectrum and power measurements.

Keeping pace

GSM standardization committees are defining new test modes for the upcoming standards HSCSD, GPRS and EDGE (enhanced data for GSM evolution). Rohde & Schwarz is keeping pace with advances: as soon as new test modes have been defined, they will be implemented in CMU200.

Rudolf Schindlmeier

[Reader service card 169/03](#)

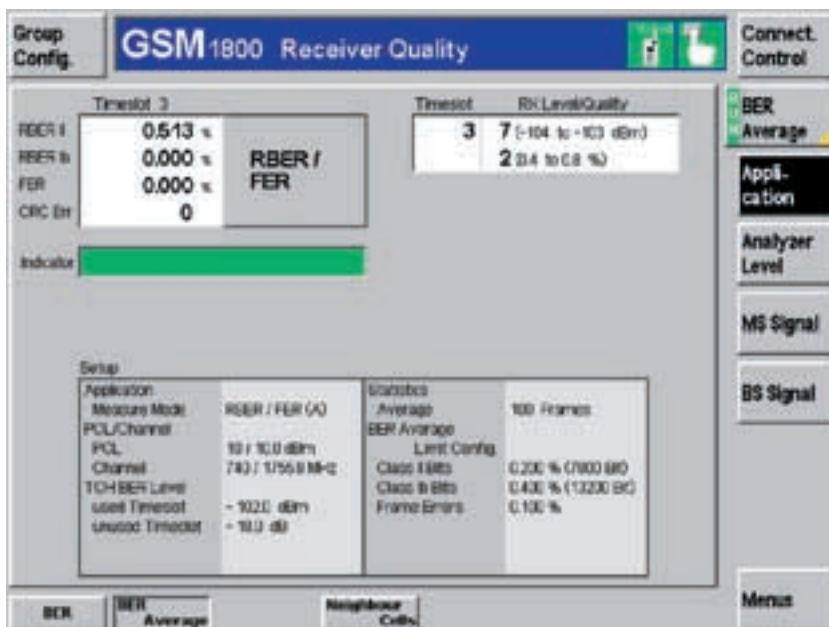

FIG 2 CMU200 categorizes the measured BER according to bit classes. A separate limit can be defined for each class

REFERENCES

- [1] CMU200: On the fast lane into the mobile radio future. News from Rohde & Schwarz (1999) No. 165, pp 4–7
- [2] CMU200: GSM power measurement – versatile, fast and accurate. News from Rohde & Schwarz (2000) No. 167, pp 24–25
- [3] CMU200: Speeded-up test of GSM mobiles without signalling. News from Rohde & Schwarz (2000) No. 168, pp 16–17

Signal Generator SMIQ

Simulating channel models for 3GPP fading tests

Thanks to its versatile architecture, SMIQ can generate signals for 3GPP (third-generation partnership project) to test mobile radios and base stations on both the uplink and downlink with channel coding [*]. Option SMIQB49 now also allows you to simulate the new channel models defined in the associated standards (3GPP TS25.104 annex B and identical in 3GPP TS25.141 annex D).

Classic channel models

The channel models defined in TS25.104 annex B2 are very similar to the scenarios used to date for mobile radio. Multipath reception of up to four paths is simulated, five different cases being looked at (FIG 1).

Cases 1, 2 and 4 simulate a pedestrian moving in the field of base stations of different power (case 1) and two or three stations of the same power (cases 2 and 4). The classic doppler spectrum, i. e. Rayleigh distribution, is used here as the fading profile.

Cases 3 and 5 correspond to reception in a vehicle (50 km/h and 120 km/h) where two or four radio signals of different delay and power are received. Here too, a Rayleigh distribution is used.

Simulating these channel models is possible with the previous option SMIQB14, but setting channel delay is only possible with time resolution of 50 ns. Options SMIQB14/B15 together with SMIQB49 achieve 1 ns resolution, which provides exact representation of the above channel models.

New channel models

In addition to these familiar channel models, two new scenarios have been introduced in 3GPP that allow assessment of the rake receiver in a mobile phone and in a base station. These are a slow change of the path with regard to time (moving propagation condition) and an erratic delay change (birth-death propagation condition).

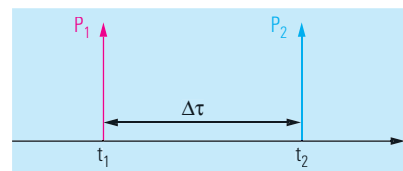

FIG 2 Two paths for moving propagation

Moving propagation

The moving propagation model tests a receiver's ability to adjust to changing delay conditions in the radio channel. This is done by using two equally powerful paths that shift relative to each other in time. Their levels remain constant. The first path (P_1) serves as a

FIG 1 Channel models of TS25.104 annex B2

	Case 1 (3 km/h)		Case 2 (3 km/h)		Case 3 (120 km/h)		Case 4 (3 km/h)		Case 5 (50 km/h)	
	Relative delay	Average power	Relative delay	Average power	Relative delay	Average power	Relative delay	Average power	Relative delay	Average power
Path 1	0 ns	0 dB	0 ns	0 dB	0 ns	0 dB	0 ns	0 dB	0 ns	0 dB
Path 2	976 ns	-10 dB	976 ns	0 dB	260 ns	-3 dB	976 ns	0 dB	976 ns	-10 dB
Path 3			20 000 ns	0 dB	521 ns	-6 dB				
Path 4					781 ns	-9 dB				

reference, the second path (P_2) moves slowly back and forth during its delay as a sinusoidal function (FIG 2).

FIG 3
Delay $\Delta\tau$ of moving path

$$\Delta\tau = DELAY_{MEAN} + \frac{DELAY_{VARIATION}}{2} \left(1 + \sin\left(\frac{2\pi \cdot t}{VARIATION PERIOD}\right) \right)$$

The delay of the reference path remains constant, the delay $\Delta\tau$ of the moving path is given by the equation in FIG 3. The variable path moves sinusoidally around a (settable) mean basic delay ($DELAY_{MEAN}$) with selectable amplitude and frequency. Usually a very low frequency and thus very low speed of delay variation are selected, because in reality the delay changes are only produced by the movement of a receiver of course. This channel model allows you to test a receiver's ability to adjust the delay of its "fingers" to the changing radio traffic field.

FIG 4
SMIQ menu for moving propagation

FREQ 100.000 000 0 MHz		LEVEL -30.0 dBm
		PEP -8.9 dBm
ASK FSIM		ALC-S&H OFF ON
ANALOG MOD	STANDARD FAD	STATE OFF ON
VECTOR MOD	FINE DELAY	STANDARD...
DIGITAL MOD	MOVING DELAY	SET DEFAULT ▶
DIGITAL STD	BIRTH-DEATH	3GPP_3_0_MOVING
FADING SIM		Reference Path
LF OUTPUT		PATH LOSS 0.0 dB
SWEEP		DELAY 0.00 μ s
LIST		Moving Path
MEM SEQ		PATH LOSS 3.0 dB
UTILITIES		DELAY MEAN 20.00 μ s
HELP		DELAY VARIATION (PK-PK) 10.000 μ s
		VARIATION PERIOD 10.0000 s

3GPP TS25.104 annex B3 recommends the following values for the parameters in the equation:

$DELAY_{MEAN}$ = delay (path 1)
 $DELAY_{VARIATION}$ 5 ms
 VARIATION PERIOD 157 s

For further tests, the SMIQ fading option allows you to change both the basic delay ($DELAY_{MEAN}$) and the parameters of variation. In addition, both paths may exhibit different levels (FIGS 4 and 5).

Birth-death propagation

In contrast to moving propagation, birth-death propagation looks at a receiver's ability to react to the disappearance and reappearance of radio signals.

Again you have a scenario with two paths: one, the delay reference, remains constant, the second (which had a different delay) is now cut out (death) and immediately cut in again with a different delay (birth). In this way you can test a receiver's ability to ignore lost paths and simultaneously make quick use of new reception possibilities.

In the channel model recommended in 3GPP TS25.104 annex B4, the two

paths swap roles after birth and death, what was the reference path now adopting the role of the variable path. The period between two birth-death operations can be varied with option SMIQ.B49, 3GPP TS25.104 recommends a period of 191 ms.

Simple installation

Simulating channel models according to 3GPP only requires installation of software option SMIQ.B49. No modifications of SMIQ hardware are necessary.

Wolfgang Kufer

REFERENCES

[*] SMIQ: Fit for 3G with new options. News from Rohde & Schwarz (2000) No. 166, pp 10–12

[Reader service card 169/04](#)

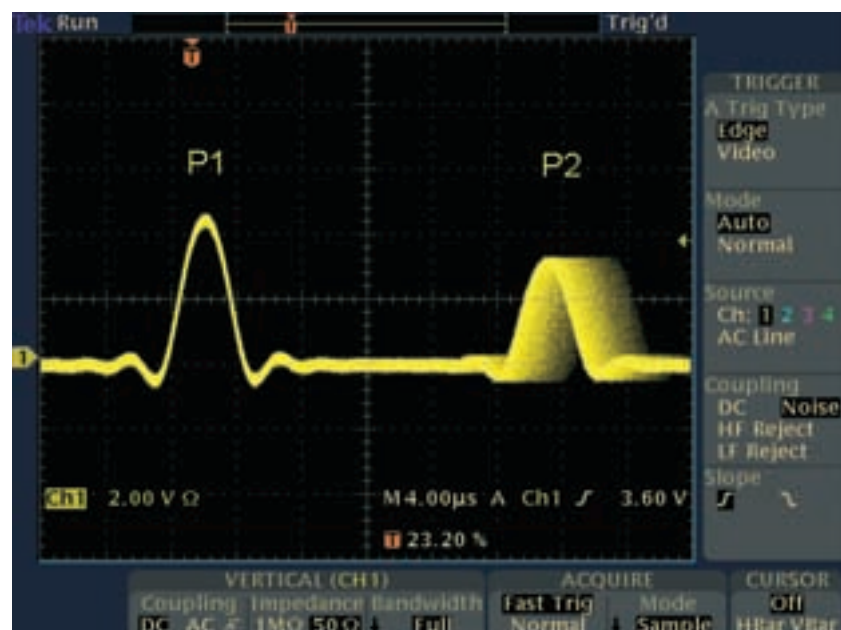

FIG 5 Picture of two paths with the persistence of the oscilloscope set to 2 s. The moving path (P2) is easily recognized

Signal Generator SMIQ

TETRA T1 test signals to standard

TETRA is developing into a major digital radio standard extending far beyond Europe. Signal Generator SMIQ generates TETRA T1 test signals using PC-based software

SMIQ-K8.

TETRA – increasing worldwide acceptance

Not only the great variety of equipment solutions proves the increasing acceptance of TETRA technology. It shows especially in the nature of the major projects already implemented, like at Oslo's airport, in the nationwide public safety network in Finland, in the Hong Kong police network, and its planned introduction on London's underground rail, scheduled for 2004.

TETRA (FIG 1) is the only standard to fulfill the extremely high security and confidentiality criteria set by the users. Its main asset, however, is the guaranteed setup time of less than 300 ms and the possibility of transmitting voice and data (*V&D*) simultaneously. Group and priority calls are extra features that clearly distinguish TETRA from GSM. Another technical specialty of the standard is that it does not require individual frequency assignments, so the frequency economy is excellent.

There are already plans to add *PDO* (packed data optimized) for pure data transmission and *DAWS* (digital advanced wireless services). *DAWS* sets up on *PDO* and is to be positioned

between the upper limit of 2 Mbit/s (for *UMTS*) and 155 Mbit/s (for *ATM*). *DMO* (direct mode operation) for instance, i. e. a direct connection between mobiles without going through a base station, is already implemented in the new Nokia THR420 handheld.

Features of TETRA Software SMIQ-K8

TETRA test signals are differentiated into T1, T2 and T3. The T1 signal is user-editable, T2 is a TETRA interfering signal and T3 a CW out-of-band interfering signal.

In its "Digital Modulation" menu, Signal Generator SMIQ is already able to generate TETRA signals with the appropriate modulation parameters $\pi/4$ -DQPSK, a modulation rate of 18 ksymbol/s and the TETRA-specific filter.

PC-based software SMIQ-K8 (FIG 2) now allows generation of T1 test signals to TETRA standard ETS 300-392/ETS 300-394. The software is designed for the startup of RF components and also to support tests to ETS 300 394-1, generating all data sequences including the control necessary to operate Signal Generator SMIQ.



...making the right connections.

FIG 1

Schematic of TETRA digital radio standard (TDMA structure with four physical channels per carrier in 380 MHz to 400 MHz band and 410 MHz to 430 MHz band, 25 kHz carrier offset, $\pi/4$ -DQPSK modulation)

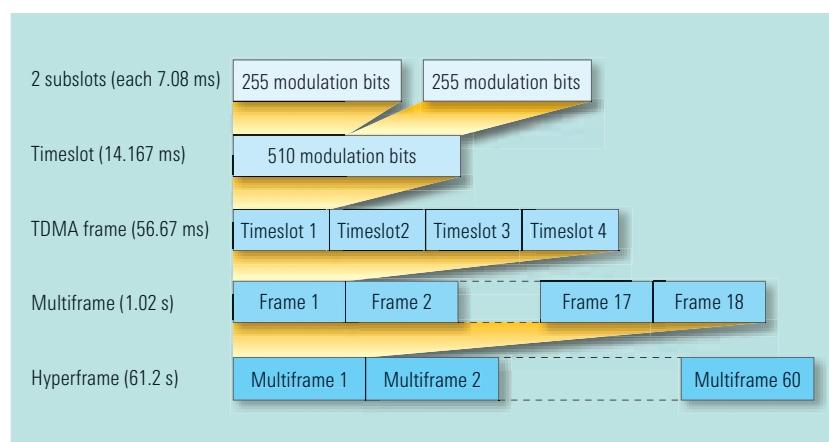

Key features of SMIQ-K8 software:

- Generation of TETRA frames (bit stream) according to the burst type selected: control burst (*CB*), normal burst (*NB*) or synchronization burst (*SB*)
- Generation of frames for uplink and downlink
- Generation of channel types AACH, BSCH, BNCH, TCH and SCH
- Channel coding for all channels. Scrambling with system code, base colour code, mobile country code and mobile network code can be selected separately
- Frame repetition can be selected via sequence length in the range of 1 to 3 multiframes (FIG 1)
- Generation of T1 test signal for *V&D* tests on *MS* and *BS*
- Selectable channel types 1 to 4, 15 and 17 for the downlink and 7 to 11, 16 and 18 for the uplink
- The bit stream is generated either as a pseudo-random sequence (CCITT o. 153) or from user-selectable sequences

Options required for Signal Generator SMIQ:

- Modulation Coder SMIQ-B20 (or predecessor SMIQ-B10)
- Data Generator SMIQ-B11
- SMIQ-Z5 for external triggering of SMIQ (recommended)
- Firmware version 3.8 or higher

PC requirements and operating systems:

- IBM-compatible PC with RS-232-C or IEC/IEEE-bus interface
- Windows™ 3.11/98/NT

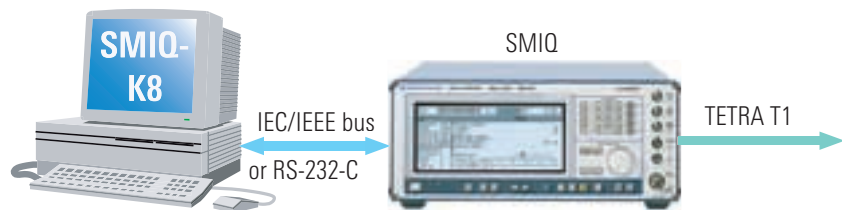

FIG 2 Signal Generator SMIQ and TETRA Software SMIQ-K8: an unrivalled team for generating standard TETRA signals

SMIQ-K8 in practice

The program starts with a default stored in the "standard.cbk" file. The active configuration file, which holds the data and control lists in SMIQ, appears in the "List Name" field. These configuration files contain all parameters previously set and saved with SMIQ-K8.

One of the main user-selectable settings of the software is the channel type. After preselecting "Downlink MS V+D Testing", channel types 1 to 4, 15 and 17 are available, and for "Uplink BS V+D Testing" channel types 7 to 11, 16 and 18. The frame types "Uplink BS V+D Testing" and "Downlink MS V+D Testing" are derived from the channel type. *PDO* packet data service is not supported. The software generates the Tx data for a complete multiframe (maximally three) for the voice and data service.

The slots required for the T1 signal can be activated independently of each other. If power ramping is active, the transmitter is blanked in the inactive slots. If no power ramping is selected, channel type 7 is inserted into the inactive slots in frames 1 to 18 on the uplink, and channel type 0 on the downlink.

There are two possibilities for the "User Data". You can select a PN9 sequence, or enter up to 73 hexadecimal characters, which are inserted into blocks 1 and 2 instead of the PN sequence, with max. 292 data bits.

Finally, all settings such as data list, control list, TETRA default setting, frequency and power are transferred to SMIQ by "Transmit to SMIQ", which then produces a standard TETRA RF signal.

Frank-Werner Thümmeler

[Reader service card 169/05](#)

Abbreviations

<i>ATM</i>	Asynchronous transfer mode	<i>ETSI</i>	European Telecommunications Standards Institute
<i>BS</i>	Base station	<i>MS</i>	Mobile station
<i>CB</i>	Control burst	<i>NB</i>	Normal burst
<i>DMO</i>	Direct mode operation	<i>PDO</i>	Packet data optimized
<i>DAWS</i>	Digital advanced wireless services	<i>SB</i>	Synchronization burst
<i>DQPSK</i>	Differential quadrature phase-shift keying	<i>TETRA</i>	Terrestrial trunked radio
		<i>V&D</i>	Voice and data

Signal Generators SML02/03

Economy class extended to 3.3 GHz



Photo 43412/6

FIG 1 With models SML02 and SML03, excellent economy-class generators up to 3.3 GHz are now available

The SML01 economy generator was launched a year ago, a signal source for the frequency range 9 kHz to 1.1 GHz [*]. Based on this successful unit, Rohde & Schwarz has developed follow-on Signal Generators SML02 and SML03, creating an instrument family that continues the excellent technical characteristics of SML01 up to 2.2 GHz (SML02) and 3.3 GHz (SML03).

Classic modulation of every kind

Like SML01 before them, SML02 and SML03 (FIG 1) also generate amplitude-, frequency- and phase-modulated RF signals. That makes them excellent RF sources for all classic receiver measurements that do not require digitally modulated signals. Using an externally applied multiplex signal, stereo modulation can also be produced.

When it comes to generating sinusoidal modulation signals, all SML models comprise an AF generator covering frequencies from 0.1 Hz to 1 MHz. Its signal can also be brought out for external applications at a separate connector. For two-tone modulation, you can operate the AF generator together with an external signal source.

Option SML-B3 upgrades all generators for pulse modulation. In addition to a high-end pulse modulator, this option includes a pulse generator with enhanced features.

All modulation modes are possible simultaneously. Only frequency and phase modulation exclude each other because they share circuitry in SML.

Advanced DDS synthesis

Where frequency accuracy and spectral purity are concerned, all SML models are almost a match for the high-end generators in the Rohde & Schwarz range. You can set frequency with crystal resolution of 0.1 Hz. With option SML-B1 (OCXO reference oscillator) frequency accuracy fulfills even the most exacting requirements.

The excellent SSB phase noise deserves special mention. For the first time, with the introduction of SML01, a typical specification of -128 dBc (at 1 GHz, 20 kHz carrier offset, 1 Hz measurement bandwidth) made its entry into this instrument class (FIG 2). The DDS-based frequency synthesis is not only notable for its excellent noise quality however. Short frequency setting times (typ.

7 ms) and high spurious suppression (typ. -64 dBc over 2.2 GHz) are further advantages.

Electronic attenuator

Tough production environments place heavy demands on the attenuator in the output of a signal generator. Precision and speed are called for, and above all maximum reliability.

That is why all SMLs are fitted with an electronic attenuator to standard. Any number of levels may be set without causing wear, and setting times of 5 ms are typical. Using special frequency response correction, level error of ± 0.5 dB up to 2 GHz and ± 0.9 dB up to 3.3 GHz is obtained. These figures can compete with those of conventional signal generators and their mechanical attenuators.

Wide range of use

Receiver measurements

Thanks to their low spurious FM of typically 0.5 Hz (at 1 GHz, 0.3 kHz to 3 kHz weighting bandwidth to CCITT), minimal SSB phase noise and high spurious suppression, these signal generators are ideal for all in-channel measurements on receivers.

The same applies if they are used as an interference source outside the receive channel (blocking measurements), because the SSB phase noise is still very low even with carrier offsets of several hundred kHz.

Sensitivity measurements require high level accuracy. Plus, the signal generator must have sufficient RF shielding – especially in the presence of unshielded receivers or units like pagers with integrated antennas. Every SML model fully satisfies these two requirements (FIGS 3 and 4).

EMC measurements

The European preliminary standard ENV 50204 has defined a test method for simulating interference caused by digital mobile phones. SML can be used here with its option SML-B3 for pulse modulation. Measurement is performed with a pulse-modulated carrier frequency of $900 \text{ MHz} \pm 5 \text{ MHz}$, with the pulse generator set to a pulse period of 5 ms and 2.5 ms pulse width.

Reference source for measuring SSB phase noise

Conventional signal generators produce their lowest frequencies by downconverting the signal from a UHF oscillator. Even at low frequencies, this method ensures good AM and FM characteristics. So SML also operates in this way

up to 76 MHz. The SSB phase noise is about the same level as at 1 GHz (FIG 2, continuous curve).

But this generator has an extra, interesting feature at the bottom of its frequency range, a mode called extended divider range. Here the RF signal is generated by frequency division, resulting in excellent figures for SSB phase noise. They easily compare with the high-grade crystal oscillators normally used as reference sources from about 10 MHz up to 30 MHz (FIG 2, dashed curve and FIG 5).

With such noise characteristics, SML is an excellent reference source for automatic test stations used to determine the SSB phase noise of synthesizers for mobile-radio base stations. Compared

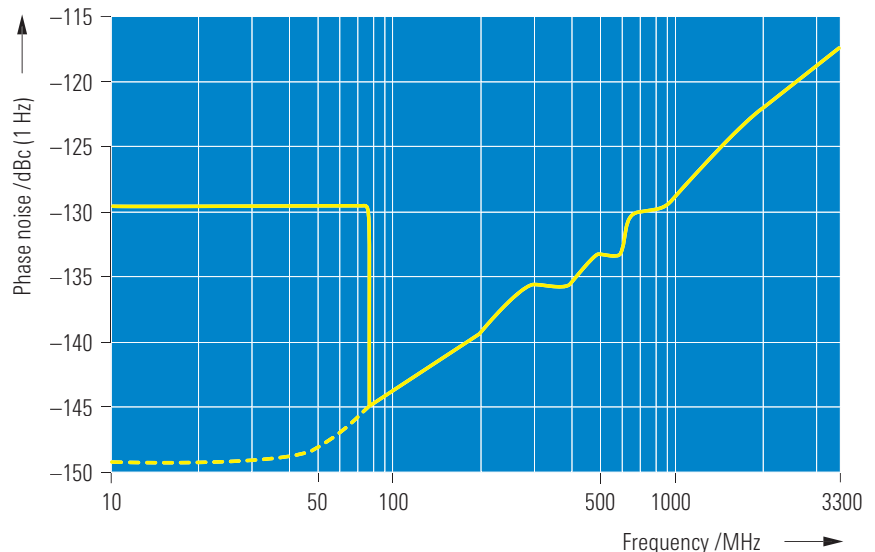

FIG 2 Typical SSB phase noise of SML03 versus carrier frequency (20 kHz carrier offset), continuous: normal mode, dashed: extended divider range

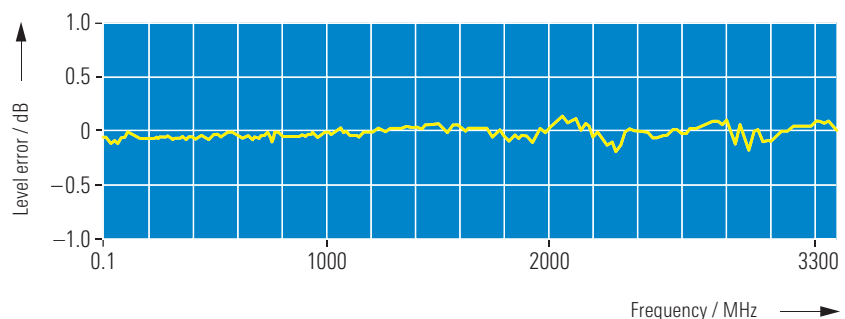

FIG 3 Typical level error at 0 dBm (SML03)

- ▶ to the crystal oscillators normally found in these applications, SML additionally offers the following benefits:
 - Frequency can be set in 0.1 Hz steps and synchronized to an external reference
 - All functions can be remotely controlled via the IEC/IEEE-bus or serial interface

Reliable and economical

The reliability of a signal generator has a lot to do with the quality of the components used and of the processes involved in its production, not forgetting due attention to every aspect of the design phase of course. The name Rohde & Schwarz ensures that SML makes no compromises in any respect.

In the unlikely event of a fault, built-in diagnostics help cut time to repair to a minimum. Not only an extremely attractive price but also low follow-on costs make SML a solid investment, particularly because it only needs calibration every three years at the most.

Wilhelm Kraemer

Condensed data of SML02/03		
Frequency range	SML02	9 kHz to 2.2 GHz
	SML03	9 kHz to 3.3 GHz
Resolution		0.1 Hz
Setting time		<10 ms
Harmonics		<-30 dBc
Subharmonics		none (f ≤1.1 GHz)
Spurious		<-50 dBc (f >1.1 GHz)
		<-70 dBc (f ≤1.1 GHz)
		<-64 dBc (>1.1 GHz to 2.2 GHz)
SSB phase noise		<-58 dBc (f >2.2 GHz)
		<-122 dBc (f = 1 GHz, 20 kHz carrier offset, 1 Hz bandwidth)
	Level	-140 dBm to +13 dBm (f >5 MHz to 3 GHz)
		-140 dBm to +11 dBm (f ≤5 MHz, f >3 GHz)
Resolution		0.1 dB
AM (3 dB bandwidth)		0 to 100% (DC to 50 kHz)
FM (3 dB bandwidth)		deviation up to 4 MHz (DC to 500 kHz)
φM (3 dB bandwidth)		deviation up to 40 rad (DC to 100 kHz)
		deviation up to 8 rad (DC to 500 kHz)
AF generator		0.1 Hz to 1 MHz
Pulse modulation (option SML-B3)		
On/off ratio		>80 dB
Rise/fall time		<20 ns
Pulse generator (option SML-B3)		
Pulse period		100 ns to 85 s

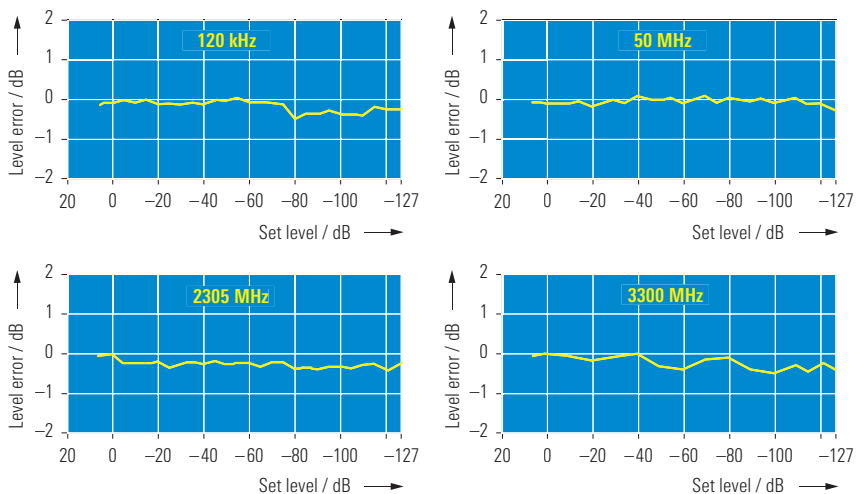

FIG 4 Level error as a function of set level

	Offset from carrier				
	1 Hz	10 Hz	100 Hz	1 kHz	10 kHz
SML 01 / 02 / 03 (measured figure)	-95 dBc	-120 dBc	-130 dBc	-138 dBc	-148 dBc
Crystal oscillator 220 (guaranteed figure)	-80 dBc	-120 dBc	-130 dBc	-140 dBc	-150 dBc

FIG 5 Signal Generator SML compared to high-grade crystal oscillator 220 (OCXO) from MTI-Milliren (USA). SML: 9.5 MHz output frequency, extended divider range activated; crystal oscillator 220: 9.5 MHz output frequency, 1 Hz measurement bandwidth

REFERENCES

[*] Signal Generator SML01: Top-class economy generator. News from Rohde & Schwarz (1999) No. 165, pp 8–10

Reader service card 169/06

I/Q Modulation Generator AMIQ / Signal Generator SMIQ

HiperLAN/2 signals with OFDM Simulation Software WinIQOFDM



Photo 43528/3

FIG 1 With Signal Generator SMIQ (top) and I/Q Modulation Generator AMIQ even long HiperLAN/2 test sequences can be generated without any problems

HiperLAN/2 and IEEE 802.11a, the new standards for wireless LAN, use OFDM modulation, which has proved itself also in digital broadcasting systems (DAB, DVB-T). With OFDM Simulation Software WinIQOFDM for generators AMIQ and SMIQ (FIG 1), Rohde & Schwarz meets the increasing demand for units that generate such signals.

HiperLAN/2 at a glance

HiperLAN/2 standard uses OFDM signals (orthogonal frequency-division multiplex) for wireless LAN. Several mobile terminals communicate with one base station. HiperLAN/2 signals consist of 64 carriers, 52 of which are modulated and transmit data and reference signals, so-called pilots. While the pilots are always BPSK-modulated, the remaining carriers used can alternatively be QPSK-, 16QAM- or 64QAM-modulated. An OFDM symbol contains a period of the total signal generated by all 64 carriers and is preceded by a guard interval. Calculation is based on inverse Fourier transform.

In terms of time, HiperLAN/2 signals are divided into MAC frames (media access control), which in turn are divided into bursts. A burst consists of a pream-

ble and a sequence of OFDM symbols, which are all modulated according to the same scheme. A HiperLAN/2 frame comprises the uplink and downlink signals (TDD) for all simultaneously active mobile terminals (TDMA).

WinIQOFDM, option K15 for generators AMIQ and SMIQ, is optimized for the simple and fast definition and generation of such complex signals (FIG 2).

OFDM signals in three steps

OFDM signals are generated in three steps. First, WinIQOFDM computes the raw signal, which is then loaded into Simulation Software WinIQSIM™ [1]* via TCP/IP as an external signal for further processing. WinIQSIM™ includes baseband filtering and optional channel

▶ distortion. The two programs communicate with each other automatically without any action on the part of the user.

Via the IEC/IEEE bus, the signal model finally reaches I/Q Modulation Generator AMIQ [2] or Signal Generator SMIQ [3], where it is physically generated. There are three possibilities (FIG 3). AMIQ is used for signal generation in the baseband (1). The generation of RF signals requires the use of SMIQ; it can either be connected as a pure I/Q modulator after an AMIQ (2) or be used as a stand-alone RF signal generator with option SMIQ.B60 (arbitrary

waveform generator). Which of the last two possibilities is used depends mainly on the length of the signal to be generated. The SMIQ.B60's memory can store HiperLAN/2 signals up to a length of six MAC frames. The memory of AMIQ02 and 03 holds 52 MAC frames, and that of AMIQ04 up to 209 frames.

User-friendly editing mode and preset symbol structures

WinIQOFDM is designed as a general synthesis program for OFDM signals. For fast and simple generation of

HiperLAN/2 signals, the software comes with a special, clearly arranged editing mode. All symbol structures possible in HiperLAN/2 are preset, and sample setups considerably facilitate further program configuration. The desired HiperLAN/2 signal is generated with just a few mouse clicks.

OFDM symbol level

WinIQOFDM generates all symbol structures defined in HiperLAN/2 including the pilots. All four modulation modes BPSK, QPSK, 16QAM and 64QAM are

FIG 2 OFDM Simulation Software WinIQOFDM, a PC program to generate HiperLAN/2 signals

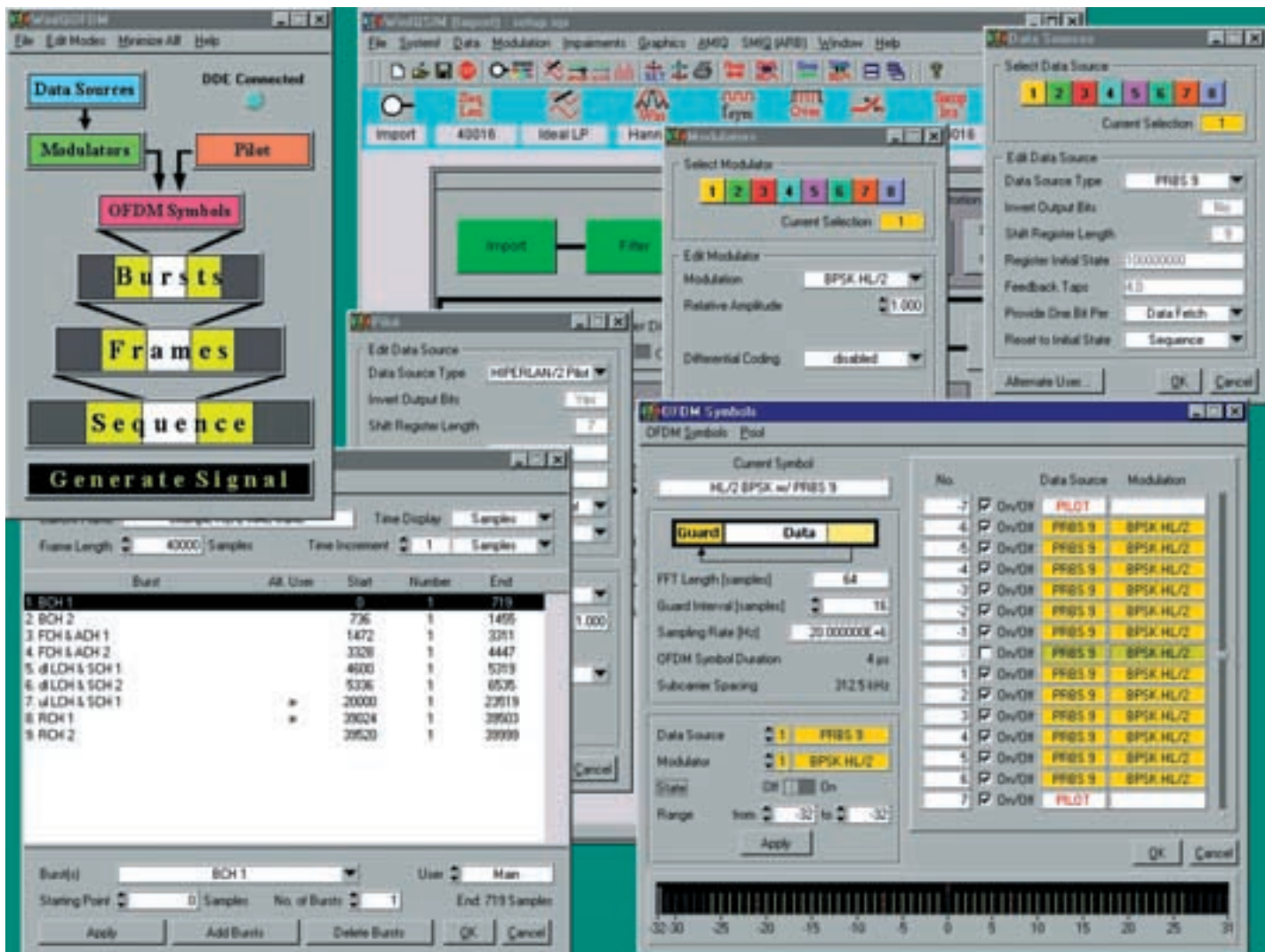

available. Useful data may consist of PRBS data and user-defined patterns as well as data read from ASCII files. Moreover, there are eight data sources available that can be freely allocated. The optional short guard mode (short guard intervals) is also supported.

TDMA framing

WinIQOFDM can also generate the time structure of any HiperLAN/2 signal. In HiperLAN/2 systems the length and sequence of bursts within the frames are dynamically defined during operation; as a result, there is an overwhelming variety of possible MAC frame structures. WinIQOFDM provides a hierarchy of bursts and frames that is user-configurable and easily edited, so the user can generate any desired MAC frame without difficulties. All necessary burst preambles are available. A model setup that can be adapted to requirements is also supplied so that untrained users can easily familiarize.

Multi-user scenarios with alternate user

Since TDD and TDMA are used within one HiperLAN/2 MAC frame, it is often necessary to simulate more than one signal simultaneously: one that is actually received by a DUT and analyzed, and another signal that represents all other active terminals and is not considered any further.

WinIQOFDM can simultaneously simulate the signals of two independent terminals with no need for redundant settings. Each burst within a frame can be assigned to one of the two terminals.

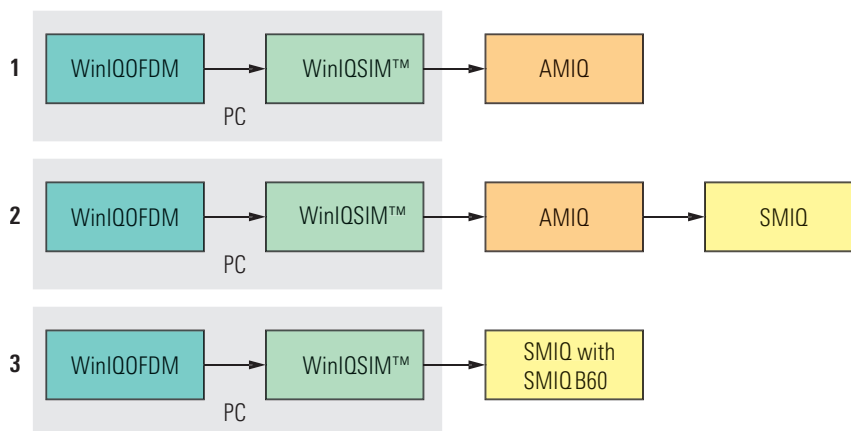

FIG 3 Generation of OFDM signals: (1) in the baseband, (2) in the RF band with AMIQ and SMIQ and (3) in the RF band with SMIQB60

IEEE 802.11a

WinIQOFDM of course allows straightforward generation of signals to IEEE 802.11a standard. Its physical layer is very similar to HiperLAN/2, the frame structure is much less complex however. Here a frame is not divided into bursts, but simply consists of a preamble and a variable number of OFDM symbols the structure of which is the same as with HiperLAN/2. The frame preamble for IEEE 802.11a is supplied as a file.

Conclusion: complex signals with a few mouse clicks

WinIQOFDM is an easy-to-operate software. Together with AMIQ or SMIQB60 it allows generation of all signals occurring in HiperLAN/2 systems. Thanks to the "alternate user", the generation of multi-user signals is particularly convenient. WinIQOFDM is not restricted to HiperLAN/2, so even test signals not complying with any standard can be computed. WinIQSIM™ handles baseband filtering and channel simulation, the user does not have to get accustomed to a new program. In AMIQ and SMIQ, two proven and powerful signal sources with sufficient bandwidth and

memory depth are available, so that even long test sequences can be generated.

The software runs under Windows™ 95 / 98 / NT / 2000.

Jochen Kraus

* WinIQSIM is a program to simulate various mobile radio signals and is supplied with AMIQ and SMIQ generators with option B60 (arbitrary waveform generator).

REFERENCES

- [1] I/Q Simulation Software WinIQSIM – New approaches in calculating complex I/Q signals. News from Rohde & Schwarz (1998) No. 159, pp 13–15
- [2] I/Q Modulation Generator AMIQ – New models 03 and 04 as well as digital I/Q output option. News from Rohde & Schwarz (2000) No. 166, pp 22–23
- [3] Signal Generator SMIQ: Fit for 3G with new options. News from Rohde & Schwarz (2000) No. 166, pp 10–12

Reader service card 169/07

Power combiners for UHF Transmitters NH / NV7000

Different transmitter power ratings made easy

The liquid-cooled UHF Transmitters NH7000 (analog TV) and NV7000 (DVB-T) [*] are notable for their high economic efficiency and reliability (FIG 4). The new cascaded power combiners for these transmitters allow implementation of a whole variety of different output power ratings.

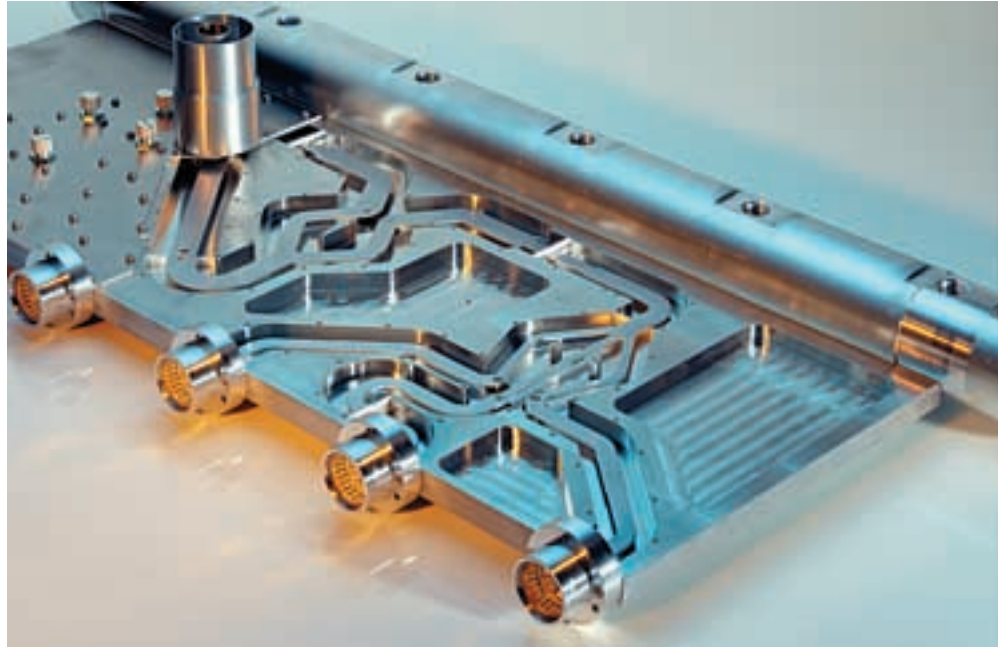

FIG 1 Triplate lines in 6-way combiner

Photo 43598/2

Cascaded throughout

The basic modules are 2-way and 3-way combiners that can be cascaded to produce 4-way, 6-way and 8-way combiners. They permit parallel connection of maximally

- six broadband amplifiers, each with 2 kW sync peak power,

- eight broadband amplifiers, each with 1.15 kW sync peak power,
- eight broadband amplifiers, each with 440 W rms power.

Thus output power of up to

- 10 kW in split mode,
 - 8.5 kW in combined mode and
 - 3.4 kW in DVB-T mode
- can be obtained in each transmitter rack.

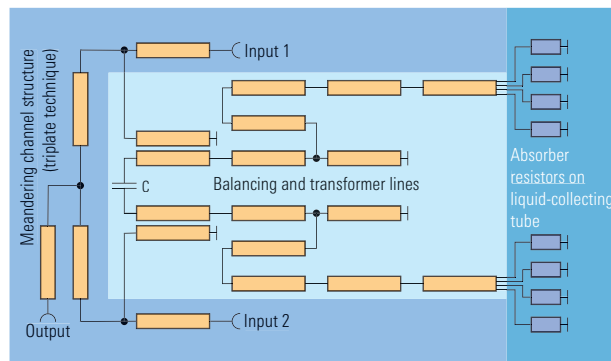

FIG 2
Schematic of 2-way
combiner

Patented decoupling

The new combiner concept is based on a modified Wilkinson bridge, the bandwidth of which was extended to the required frequency band of 470 MHz to 862 MHz by a patented decoupling circuit (FIG 2). Thus a return loss of ≥ 30 dB for the entire band can be obtained at each combiner input. In the event of a

fault, i.e. if one or more amplifiers fail, broadband decoupling at the operating amplifiers ensures a return loss of at least ≥ 22 dB.

The transmitter output power available after n amplifiers have failed is reduced to

$$P_n = P_{\text{tot}} \cdot [(m-n)/m]^2.$$

(P_{tot} = total power when all amplifiers are operative, m = total number of amplifiers)

Parallel-connected absorber resistors and their transformer lines (FIG 3) are integrated in the PCBs responsible for combiner symmetry so that expensive cable connections and separate absorber blocks are superfluous. The heat produced in case of a failure is dissipated

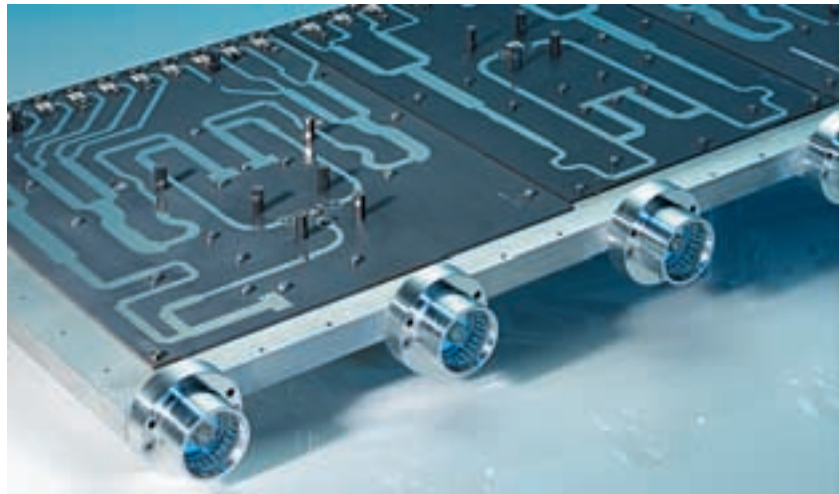

Photo 43598/4

FIG 3 Balancing and transformer circuits of 6-way combiner

via a liquid-collecting tube fixed to the combiners.

Maximum power transmission

2-way and 3-way combiners are the basic modules. Combiners with four and more inputs are always made up of one or two series-connected 2-way combiners. This system of cascaded modules permits multiple use of PCBs and the employment of a triplate technique on the RF lines, which add the input power to one output. A meandering channel structure is milled into the combiner body, containing an inner conductor made up of a single piece (FIG 1). This ensures maximum power transmission and minimum transmission loss. Auto-

matic connectors are used for the sturdy combiner inputs (RL13-30), which are fitted to the front of the board so that the combiner is orthogonal to the amplifier plug-ins. This allows amplifiers to be replaced without interrupting operation and guarantees easy access to all transmitter components.

Ludwig Moll

REFERENCES

[*] UHF Transmitter Family NV / NH 7000 – Liquid-cooled TV transmitters for terrestrial digital TV. News from Rohde & Schwarz (1999) No. 165, pp 11–13

[Reader service card 169/08](#)

FIG 4
DVB transmitter of NV 7000 family accommodated in a single rack



Photo 43392/1

Condensed data of power combiners for NH / NV 7000

Frequency band	470 MHz to 862 MHz
Return loss at inputs during operation	≥ 30 dB
Return loss at inputs on failure	≥ 22 dB
Transmission loss (depending on combiner type)	0.05 dB to 0.18 dB
Sync peak power per combiner input	max. 2 kW
RF inputs	RL 13-30
RF output	RL 25-58

Multichannel Video Quality Analyzer DVQM

Multichannel monitoring in digital TV broadcasting networks

The introduction of the European DVB standard produced a virtually overnight increase in available TV programs. This meant new requirements for automatic, continuous monitoring of picture and sound quality in digital TV broadcasting networks in terms of price and space efficiency. Rohde & Schwarz has taken up the challenge and, with Multichannel Video Quality Analyzer DVQM, presents a highly compact but powerful test platform for simultaneously monitoring up to twelve TV channels.



Photo 43318/6

FIG 1 EMMY award for the measurement principle of Digital Video Quality Analyzer DVQ (shown here). DVQM (FIG 2) is the space-saving multichannel version of DVQ

Modelled on DVQ

DVQM is a multichannel extension of the successful Digital Video Quality Analyzer DVQ [1] (FIG 1), whose measurement principle won it the EMMY award of the National Academy of Television

Arts and Sciences in the USA (Newsgrams on page 46). DVQM does away with all components for manual operation. The hardware concept of DVQ was adopted unchanged to form the basis for each measurement channel in the multichannel DVQM. Even the DVQ firmware

remains unaltered for use in DVQM. So a measurement system consisting of individual DVQs can be ported to DVQM and extended to maximally twelve channels without modifying the remote-control software.

Flexible and compact

DVQM is accommodated in a 19" rack of eight height units (FIG 2). The basic model contains two DVQ boards; the compact rack can hold up to twelve measurement modules. Thanks to a simple plug-in design, the boards can be retrofitted or modified by the user. Compared to a solution with single DVQs, the 70% space saving is impressive, since twelve DVQs would require 24 height units.

Monitoring functions

DVQM offers the following measuring and monitoring functions for each of a maximum of twelve channels:

- Automatic, cyclic program sequencing (SCAN) in the transport stream multiplex
- Detection of picture loss, picture freeze and sound loss
- Internal error report
- Internal MPEG2 decoding (also professional profile 4:2:2 with max. 50 Mbit/s)
- Signal inputs TS-ASI (max. 70 Mbit/s) and ITU-R BT601 (SDI)
- Remote-control protocols SCPI (via RS-232-C or 10BaseT) and SNMP (via 10BaseT)
- Realtime picture quality analysis, with or without reference signal (option)

Integral remote control

DVQM is entirely remotely controlled, each of a maximum twelve modules separately. The front panel has just four



Photo 43 629/1

FIG 2
Less striking in its appearance, DVQM convinces more by what is inside

LEDs per channel for visually signalling important devices statuses. The instrument has all the protocols and interfaces required by the market at present. It supports the SCPI protocol (standard commands for programmable instruments), and each measurement module provides remote-control SNMP (simple network management protocol), which is used for the management of systems, such as communication or transmission networks, installed wide apart.

Remote control via the 10BaseT network interface offers a higher transfer rate and the benefit of simpler system con-

figuration. For example, the twelve modules are connected to an Ethernet hub (standard PC accessory) by a network cable and another network cable is linked to a local PC.

New PC software for MPEG2 monitoring

Rohde & Schwarz offers the DTV NetView software for DVQM, which clearly displays the status of all channels monitored in a network. The program also presents the results of detailed MPEG2 protocol analyses, determined

FIG 3 DTV NetView software for DVQM displays the monitoring status of all channels

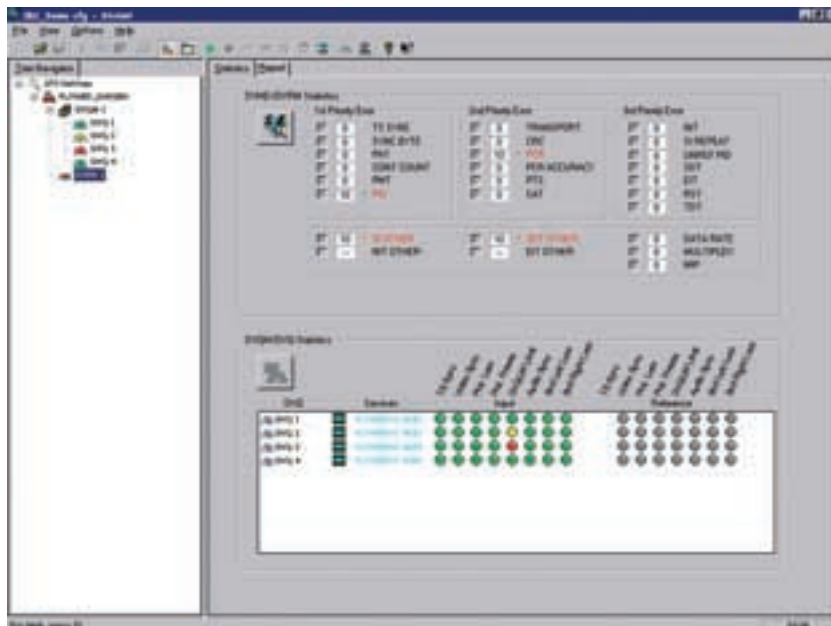

▶ with MPEG2 Measurement Decoder DVMD or Realtime Monitor DVRM, in a separate window. For detailed analysis of the picture quality of single TV channels over a long period of time, Rohde & Schwarz Quality Monitor™ software can be directly started by mouse click from the DTV NetView user interface.

The network topology including all Rohde & Schwarz measuring instruments is communicated to the software by a configuration file. FIG 3 illustrates as an example the software user interface with a network comprising one Realtime Monitor DVRM and four DVQ modules in DVQM.

Numerous applications

The major field of application of DVQM is automatic monitoring of central nodes in digital TV transmission networks. At these points, such as satellite uplinks, the number of programs is highest, and use of the multichannel analyzer is most useful here to ensure QoS.

The following scenarios are possible for use of DVQM, assuming that the input signal is a transport stream multiplex of several TV programs:

One DVQM channel per TV program

The asset of this scenario is continuous monitoring of all programs, but it requires a larger number of monitoring channels. The concept is only useful if very few transport streams (TS) are to be monitored or permanent and interruption-free monitoring of all programs is essential.

One DVQM channel per transport stream

This is an optimum compromise between investment in test equipment and reliable detection in good time of picture and sound degradation in transmission

networks with a large number of TS. The programs of a TS are not decoded and monitored permanently but instead cyclically with an automatically sequencing program (SCAN) for a set time interval.

Options for CA systems

The options for CA (conditional access) systems extend the field of application of DVQM to the monitoring of transmission channels with encrypted content [2]. The five major CA systems are currently supported, others are in preparation (FIG 4).

The CA options need one slot in DVQM to form a functional unit together with a DVQ board. When fully configured, one DVQM therefore includes up to six such pairs, which can also be retrofitted by the user.

It was in no small part thanks to the CA options that Rohde & Schwarz won a first large-scale order from Europe's leading satellite operator SES-Astra for video and sound quality monitoring in a digital TV transmission network [3].

Thomas Bichlmaier

Betacrypt/		
BetaDigital	✓	(DVQM-B16/02)
Betacrypt/DTAG	✓	(DVQM-B16/03)
Betacrypt/ORF	✓	(DVQM-B16/04)
Conax	✓	(DVQM-B10)
Irdeto	✓	(DVQM-B11)
Mediaguard	✓	(DVQM-B12)
Nagravision	✓	(DVQM-B10)
Viaccess	✓	(DVQM-B10)
Others		in preparation

FIG 4 CA standards available for DVQM

REFERENCES

- [1] Optimizing digital TV networks – QoS maintained automatically. News from Rohde & Schwarz (2000) No. 166, pp 38–39
- [2] Digital Video Quality Analyzer DVQ – The key to high picture quality. News from Rohde & Schwarz (2000) No. 168, pp 20–21
- [3] Newsgrams. News from Rohde & Schwarz (2000) No. 166, p 41

[Reader service card 169/09](#)

Condensed data of DVQM

Basic unit

Modules (channels)	2 (max. 12)
Enclosure	19", 8 HU
Weight	approx. 25 kg
Power consumption	max. 300 W

CA options

Standards	see FIG 4
Input	TS-ASI (DVB A010), 75 Ω, max. 50 Mbit/s
Output	TS-ASI (DVB A010), 75 Ω, max. 50 Mbit/s

Continued from No. 168

Measurements on MPEG2 and DVB-T signals (2)

Part 1 of the refresher topics dealt with key measurements in the studio as well as monitoring of the feeder link between the studio output and the transmitter input. This time, measurements on the actual DVB-T transmitter are looked at.

Measurements at the transmitter input

The first point of measurement is the transmitter input, from where the incoming MPEG2 transport streams (TS)¹⁾ are routed to the DVB-T modulator. For optimal transmitter monitoring, the MPEG2 parameters and the TS protocol should be evaluated. It must be ensured that the data intended for transmission contain the correct programs and data and that the quality of the outgoing picture meets appropriate standards. Especially in statistical multiplex mode²⁾, certain minimum quality standards as determined by the MPEG2 coding have to be met even under extremely poor conditions of reception. The following param-

eters are measured at the transmitter input:

- all events recorded in monitoring/report,
- *PAT, CAT, NIT, PMT, SDT* and *EIT*, which may reveal TS routing errors,
- *MIP* with relevant *SFN* synchronization data (not required in *MFVs*) and modulator settings [5],
- agreement of *NIT* and *MIP* information, ▶

1) Abbreviations in italics: Explanation in "Glossary" box on page 31 and part 1 of refresher topics.

2) In this mode more programs are possible simultaneously in the TS multiplex: programs that happen to have a low data rate surrender capacity to programs needing a high data rate.

FIG 8 Monitoring of transmitter input in single-frequency networks

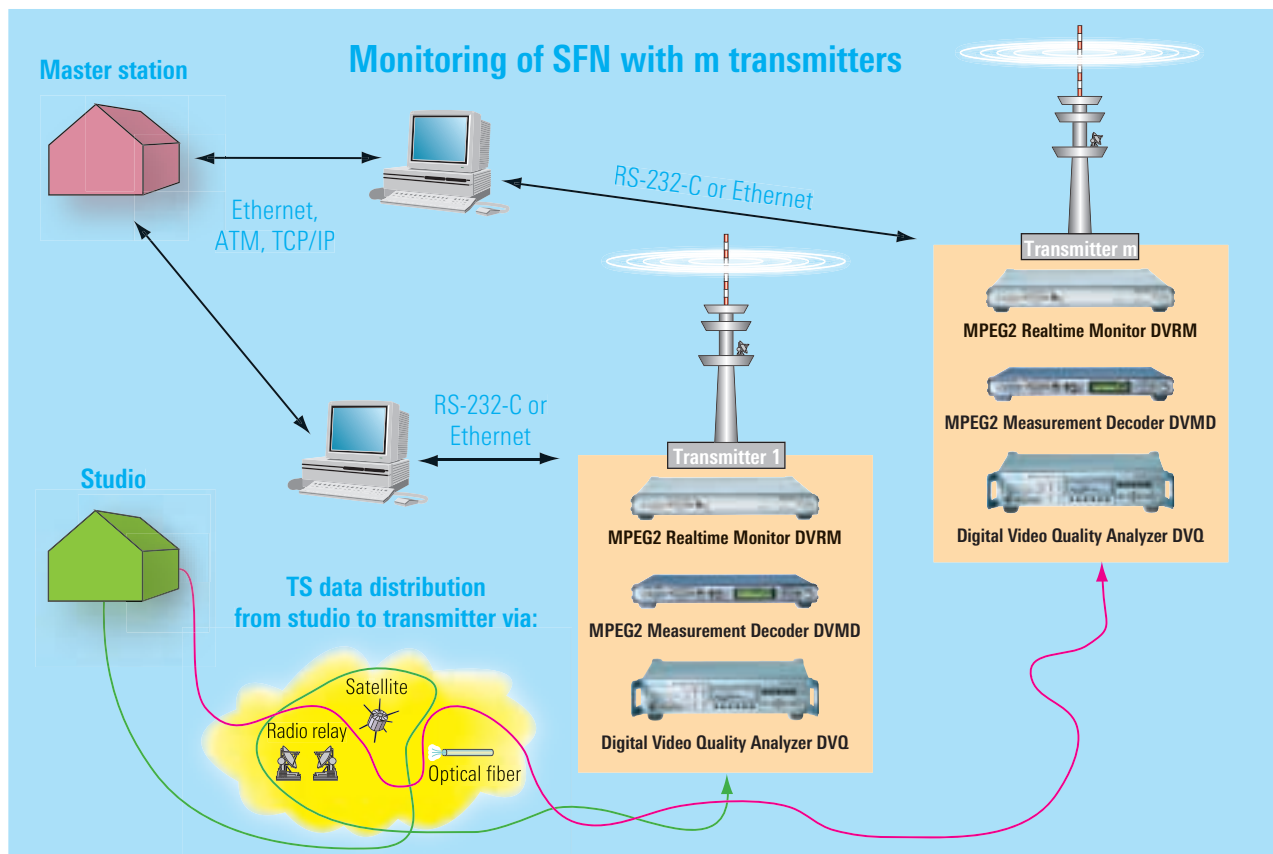

- identification of *TS*, transmission media and transmission networks,
- data rate of incoming *TS* and elements of the individual programs,
- picture quality, determined from MPEG2 artifacts.

In an *SFN*, the above tasks can be handled by a PC-controlled remote monitoring system (FIG 8). Each transmitter is assigned such a system, which in its minimum configuration consists of a PC, Decoder DVMD or Monitor DVRM, and Analyzer DVQ. It provides optimal monitoring of the *TS* at each transmitter input to ensure compliance with a program provider's specifications. At the transmitter input it is sufficient to analyze the programs and data of the *TS* one after the other by calling the *PIDs* of the associated *PMTs*. At the studio output, on the other hand, each program should be assigned a Decoder DVMD or Realtime Monitor DVRM or Video Quality Analyzer DVQ to provide comprehensive monitoring (see also part 1 of the refresher topics). To analyze the picture quality of several programs, it is advisable to use Multichannel Video Quality Analyzer DVQM, which integrates up to twelve DVQs in a highly compact configuration (page 26).

The measurement and monitoring data are taken via RS-232-C or Ethernet interfaces to the station computer. This not only manages the *TS* input data but also controls all other measurement and organization tasks of the station. From

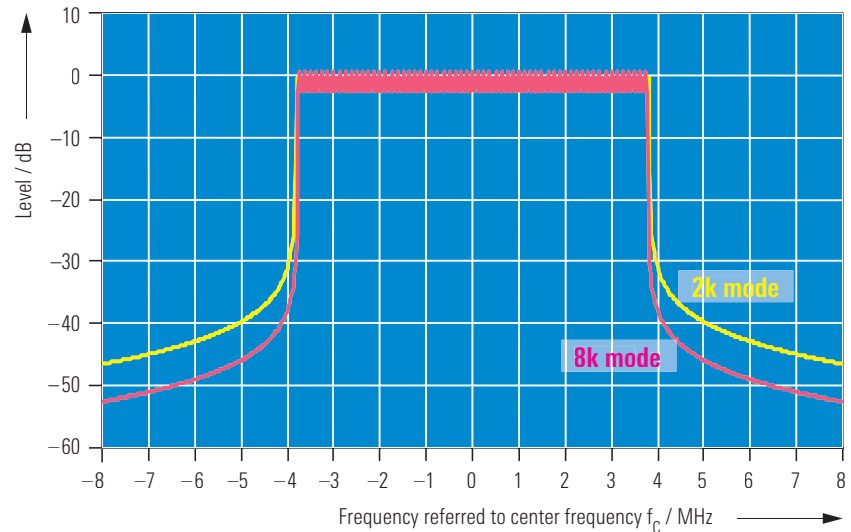

FIG 10 DVB-T spectrum for 2k and 8k mode with guard interval of $\tau = 1/4$

here the data are transmitted in ATM mode, using SDH or PDH protocols, by the Internet or another medium to the *SFN* master station for central analysis. This gives the operator an overview of the status of the entire network.

Not only the protocol of the MPEG2-coded programs and data of the *TS* are evaluated in this way, the *MIP* contents too are subjected to a final check at the transmitter input before they are put on the air. Decoder DVMD with the optional Stream Explorer™ opens the *TS* packets with the address 0x0015 and displays the information required for synchronization of the *SFN* in interpreted form, e.g. in plain-text tables (see also part 1 of the refresher topics).

Measurements on DVB-T exciter

The *TS* to be transmitted is routed to the input of the DVB-T exciter via an *ASI* interface. First the contents of the *MIP* are decoded. The packet includes the configuration data for the DVB-T coder and modulator, which performs direct frequency conversion to the RF. So this information can also be used to set the operating mode. This requires due care, however, since the *NIT* also transmits these data, and agreement between the *MIP* and *NIT* data is essential. This is checked already at the transmitter input. The DVB-T receiver evaluates the *NIT* data and, if they differ from the *MIP* data, can neither demodulate nor decode.

The DVB-T modulator synchronizes to the *SFN* timing conditions by means of the *STS* (system time stamp) and other *MIP* information. This is followed by signal processing in conformance with EN 300 744 [7].

The digital baseband signal generated by the above procedure is applied in the form of real and imaginary components to the digital precorrector of the exciter. The precorrector ensures



FIG 9 MPEG2 Realtime Monitor DVRM [6]
Data sheet PD 757.5566

optimal equalization of amplitude frequency response, group delay and linearity of the power amplifiers. By varying the instantaneous amplitude and phase, the required high linearity of the DVB-T transmitter characteristic and frequency response is obtained at the output of the power amplifiers. The digitally pre-corrected DVB-T signal is D/A-converted and then directly converted to the RF without any intermediate IF stage.

DVB-T spectrum

Looking at the theoretical DVB-T spectrum in FIG 10, you see a flat trace with a ripple of about 3 dB in the useful region, the ripple depending on the guard interval used. At the band limits, the signal drops sharply over the width of a carrier spacing, then the trace is relatively flat again. In the 2k mode the knee is located about 10 dB higher than in the 8k mode.

With higher frequency resolution, the inserted guard intervals are clearly discernible. FIG 11 shows the range from -3.85 MHz to -3.78 MHz in the 8k mode, where the single carriers can be recognized. The red curve shows the signal characteristic for $\tau = 1/4$. In the useful band the single carriers are distinguishable, even though the dips between them are just about 3 dB. By contrast, the out-of-band components are markedly flatter.

The green curve shows the signal characteristic for $\tau = 1/32$. In the useful band the single carriers can hardly be distinguished, the dips between them are less than 1 dB. The out-of-band components in this case have much more pronounced ripple. The yellow curve shows the characteristic for $\tau = 0$, i. e. without any guard intervals. In the useful band the spectrum is absolutely smooth, whereas the out-of-band components are characterized by deep dips occurring at carrier spacing.

FIG 11
Detail of spectrum
with different guard
intervals
(red: $\tau = 1/4$,
green: $\tau = 1/32$,
yellow: $\tau = 0$)

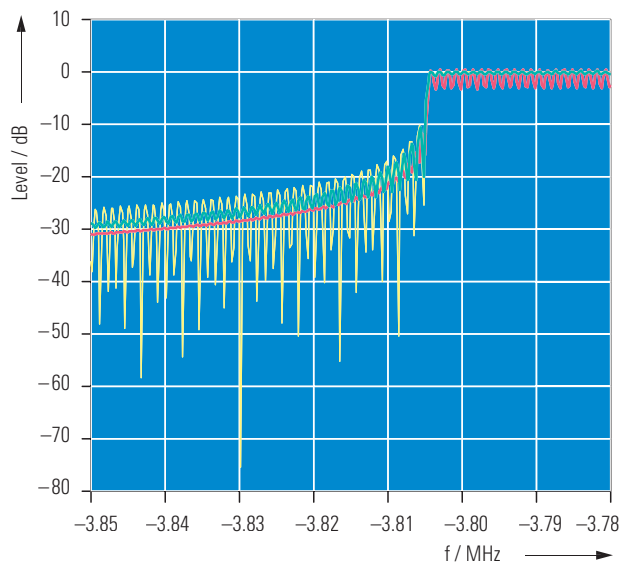

FIG 11 shows that orthogonality between the single carriers exists only for $\tau = 0$. As soon as a guard interval is added, this condition is no longer fulfilled. The guard interval is blanked in the receiver, thus restoring orthogonality.

FIGs 10 and 11 illustrate a basic problem in DVB-T spectrum measurement: in the useful region there is always a certain amount of ripple as a function of the guard interval. How, then, do you measure the useful spectrum?

And there is another problem: the out-of-band components always have a basic ripple as well as a steep decline by about 15 dB at a spacing of one carrier from the last useful carrier. Then the out-of-band spectrum is relatively flat and, with a guard interval of $\tau = 1/32$, has up to 10 dB deep dips at carrier spac-

ing. Where do you measure the shoulder distance?

Measurement of useful spectrum

Modern spectrum analyzers provide the answer: with resolution bandwidth much wider than the carrier spacing, the dips of the useful spectrum are averaged to obtain a smooth characteristic. In this way, satisfactory results are achieved even with a medium-priced analyzer. However, it must be remembered that the reference for all measurements is the positive envelope of the spectrum; so the analyzer must have a peak detector.

State-of-the-art spectrum analyzers like FSP (FIG 12) and FSEx from Rohde & Schwarz fully meet the requirements for

Glossary

<i>ASI</i>	Asynchronous serial interface	<i>ICI</i>	Inter-carrier interference
<i>CAT</i>	Conditional access table	<i>LO</i>	Local oscillator
<i>CPE</i>	Common phase error	<i>RBW</i>	Resolution bandwidth
<i>EIT</i>	Event information table	<i>SDT</i>	Service description table
<i>ENF</i>	Equivalent noise floor	<i>STS</i>	System time stamp

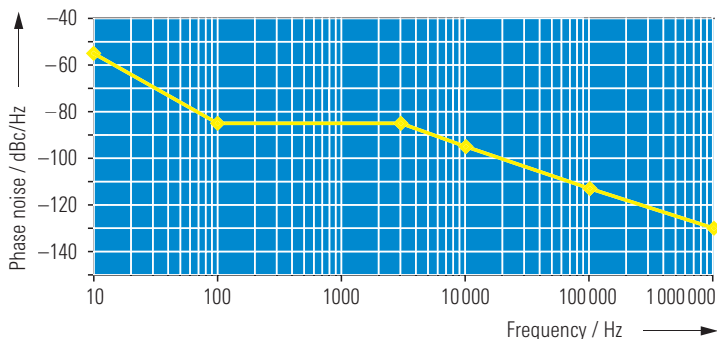

FIG 13
VALIDATE draft
standard AC106 for
phase noise measure-
ment

The frequencies for measuring *I/C* are defined by ETR 290 [1] as follows:

COFDM mode	f_A / kHz	f_B / kHz	f_C / kHz
2k	4.464	8.928	13.392
8k	1.116	2.232	3.348

However, the level values at points A, B, and C of the mask (FIG 14) are not yet defined. The frequencies are *n* times the carrier spacing in each case.

Sigmar Grunwald

(to be continued)

► transmitter measurements in terms of dynamic range and frequency range and feature both a peak and an rms detector.

Just as with analog transmitters, measurement of the second harmonic and determining *L0* phase noise are musts with DVB-T transmitters too.

Measurement of phase noise

A spectrum analyzer should be available at each transmitter site of an *SFN* or at least for servicing so that the above measurements can be performed.

The standards proposed by the European VALIDATE work group are very restrictive; see draft standard AC106 for phase noise in the 2k mode illustrated by FIG 13. It shows that phase noise suppression as low as -55 dBc/Hz has to

be attained just 10 Hz from the *L0* frequency. So the *RBW* (resolution bandwidth) must be much smaller than 10 Hz, the preferable value being 1 Hz. It also means that a measurement must not take too long, otherwise the reference frequency of the spectrum analyzer may change. Phase noise at a spacing of one carrier from the *L0* frequency is already defined as *ENF* (equivalent noise floor).

There are two types of phase noise in COFDM modulation:

- *CPE* (common phase error): signal distortions that are common to all carriers. This error can (partly) be suppressed by channel estimation using the continual pilots.
- *I/C* (inter-carrier interference): non-correlated noise superimposed on all carriers. This type of signal degradation cannot be corrected.

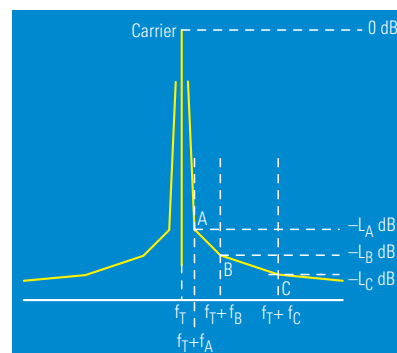

FIG 14 Mask for phase noise



FIG 12 Spectrum Analyzer FSP [8]
Data sheet PD 757.5137

FSP3	9 kHz	to	3 GHz
FSP7	9 kHz	to	7 GHz
FSP13	9 kHz	to	13 GHz
FSP30	9 kHz	to	30 GHz

Photo 43404/3

REFERENCES

- [5] TS 101 191 Digital Video Broadcasting (DVB); DVB Mega-Frame for Single Frequency Network (SFN) Synchronisation
- [6] MPEG2 Realtime Monitor DVRM – digital broadcast networks: operation secured. News from Rohde & Schwarz (1999) No. 165, pp 14–15
- [7] EN 300 744 Digital Video Broadcasting (DVB); Framing Structure, Channel Coding and Modulation for Digital Terrestrial Television
- [8] Spectrum Analyzer FSP: Medium class aspiring to high end. News from Rohde & Schwarz (2000) No. 166, pp 4–7

DF antennas for every purpose

From HF to UHF, stationary and mobile

When Rohde & Schwarz launched a new generation of digital direction finders several years ago, a new family of DF antennas appeared at the same time and has been continuously added to. The antennas can be used for both Digital Monitoring Direction Finders DDF0xM and Digital Scanning Direction Finders DDF0xS, which feature three receiver modules. A separate antenna family is provided for the single-channel DDF 190.



Photo 43 178/3

FIG 1 Interferometer DF Antenna ADD011, combined with Adcock Antenna ADD012 (monopoles in background, right)

The new generation of digital direction finders [1, 2, 3] uses either the classic Watson-Watt method or the advanced correlative interferometer principle. For both, Rohde & Schwarz offers a comprehensive selection of antennas for stationary and mobile use covering the range from HF through UHF (FIG 4).

DF antennas for shortwave

Because of the large wavelengths in the shortwave range from 1000 m to 10 m, DF antennas for this purpose are usually also large. All shortwave antennas from Rohde & Schwarz range from 0.3 MHz to 30 MHz.

Correlative interferometer

The correlative interferometer determines the azimuth of a signal and its elevation. The advantage is that the loca-

tion of a transmitter can be determined with only one direction finder by considering the ionosphere (SSL: single station location), provided however that the signal is only reflected once by the ionosphere (single-hop propagation).

For the correlative interferometer there are two types of DF antenna: ADD010 and ADD011. The latter consists of nine crossed-loop antenna elements arranged on the circumference of a circle 50 m in diameter (FIG 1). Thanks to their vertical antenna pattern, crossed loops detect signals that arrive as sky-waves up to elevation angles of almost 90°.

The antenna elements can be folded up, mounted on tripods and are thus suitable for stationary and transportable use. ►

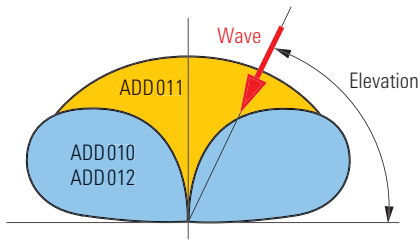

FIG 2 Vertical patterns of ADD011, consisting of crossed-loop elements, and ADD010 and ADD012, both designed with rod antennas

- ▶ DF Antenna ADD010 is intended for mobile applications in the same frequency range. It consists of nine monopole elements, also arranged in a circle 50 m in diameter. They can be set up and dismantled faster, and take up less space during transport. In this case the vertical pattern only allows detection of signals up to elevation angles of about 60° (FIG 2). In particular when determining elevation, major errors can be produced by signals with steep angles of incidence. With nine elements and a triple receiver arrangement, sequential sampling is necessary, requiring extended signal duration. On the other hand, the correlative interferometer stands out for its high accuracy and stability.

Adcock/Watson-Watt direction finder

DF Antenna ADD012 is intended for stationary applications using the Watson-Watt method. It is in the nature of Adcock antennas that they do not cover as wide a frequency range as DF antennas for a correlative interferometer. ADD012 may consist of one or two circular arrays, each with eight monopoles, and one central antenna, the circles being 7 m and/or 22 m in diameter. Since the Watson-Watt method only gives you the azimuth and no elevation, the vertical pattern of the monopole plays a minor role (FIG 2). The signals of the Adcock antenna are processed simultaneously during the Watson-Watt evaluation, i.e. without any switching steps, so signals of shorter duration are detected and higher search speed is possible.

If the available space is limited, on ships or vehicles for instance, there is no alternative to compact DF antennas, but these can only be implemented for Watson-Watt. For vehicular use or temporary installation on a tripod, HF DF Antenna ADD 119 is the best choice. It can be used in single- and three-channel systems.

ADD015 was specially designed for shipboard use and so that an extra VHF-UHF DF Antenna ADD 150 can be mounted on its tip [4].

Modernization of older systems

Users in the shortwave range in particular will modernize their Adcock/Watson-Watt direction finder from time to time, but wish to continue using the generally rather elaborate Adcock component. With Direction Finder DDF01M or DDF01S, this is quite straightforward by connecting Antenna Interface GX060 between DF antenna and DF instrumentation.



Photo 43073/2

FIG 3 Together, correlative interferometer antennas ADD 051 (= ADD 050 with ADD 150) and ADD 070 (cylinder below) cover the frequency range 20 MHz to 3000 MHz

DF antennas for VHF-UHF

Apart from elevation, the same fundamentals apply to DF methods in the VHF-UHF range. Here too, there are DF antennas for evaluation by the correlative interferometer or Watson-Watt principle, for both stationary and mobile use.

Correlative interferometer

A wide range of antennas is available for the correlative interferometer. Compact VHF-UHF DF Antenna ADD 150 covers 20 MHz through 1300 MHz in a stationary or mobile role. Due to its compact size, performance is slightly limited at the bottom end of the frequency range (sensitivity, response to multipath propagation). This deficiency can be reduced in mobile use by approaching the transmitter. In stationary mode, VHF Antenna ADD050, which is optimized for the 20 MHz to 200 MHz range, can be added (together they form DF Antenna ADD 051, FIG 3). UHF DF Antenna ADD070 (FIG 3), both mobile and stationary, covers the range between 1.3 GHz and 3 GHz.

GSM frequencies 900 MHz/1800 MHz and 1900 MHz are gaining in importance. Organizations responsible for correct use of the frequency spectrum are very much interested in locating sources of interference in these bands – especially in built-up areas. DF Antenna ADD 170, which is especially immune to reflection, was developed for this purpose.

Adcock/Watson-Watt direction finder

The Watson-Watt method can also be utilized with compact DF Antenna ADD 155 covering 20 MHz to 650 MHz.

Antennas for DDF190

In the shortwave range, DDF 190 operates in Watson-Watt mode. HF DF Antenna ADD 119 is designed for both the two three-channel DDF0xM and DDF0xS direction finders and single-

FIG 4
Antenna selection for
Digital Direction
Finders DDF0xM,
DDF0xS and
DDF190
 (yellow: mobile
 and stationary,
 green: stationary)

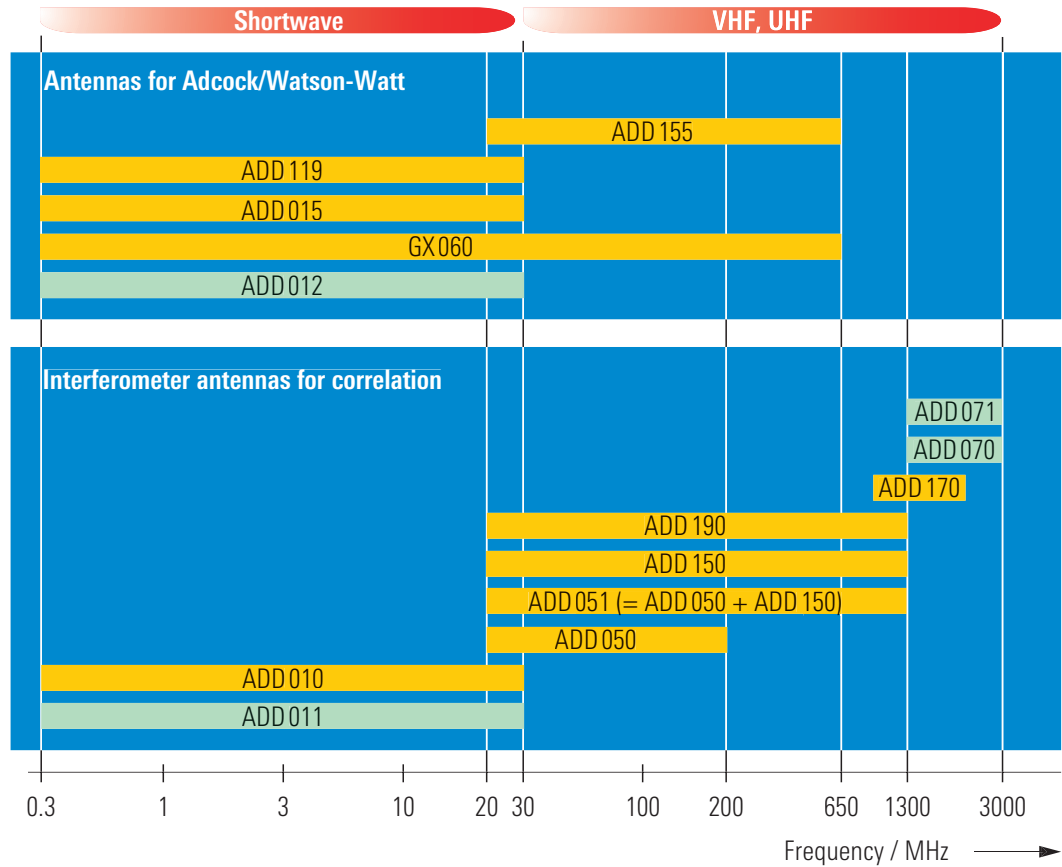

channel DDF 190. DF Antenna ADD 190 for the VHF-UHF range (30 MHz to 1300 MHz) is almost identical to ADD 150 but operates with a single channel.

UHF DF Antenna ADD 071 (1.3 GHz to 3 GHz) is very similar to ADD 070. The antenna voltages of ADD 190 and ADD 071 are evaluated by the correlative interferometer method. Because of the single-channel evaluation, a multiplex method patented by Rohde & Schwarz is additionally implemented in DDF 190 and its antennas.

Franz Demmel; Ulrich Unselt

REFERENCES

- [1] Digital Monitoring Direction Finders DDF0xM – State-of-the-art monitoring direction finding from HF to UHF. News from Rohde & Schwarz (1996) No. 150, pp 22–25
- [2] Digital Scanning Direction Finders DDF0xS – Fast direction finding of broadband and shortterm signals. News from Rohde & Schwarz (1998) No. 158, pp 21–23
- [3] VHF-UHF Direction Finder DDF 190 – Digital direction finding from 20 to 3000 MHz to ITU guidelines. News from Rohde & Schwarz (1996), No. 152, pp 30–32
- [4] Shortwave direction finding on ships. News from Rohde & Schwarz (1999) No. 162, pp 29–30

SITLink

Secure and confidential communication on leased lines

Photo 43627/1

Everyone is talking about mobile communication, wireless around the world using exorbitant bandwidths. The leased line usually recedes into the background when such solutions are discussed. But it is often forgotten that the leased line is an approved communication medium for transmitting large data quantities at low cost. The purpose of SITLink is to provide confidential communication on such transmission routes.



FIG 1 SITLink for confidential communication on synchronous leased lines up to 2 Mbit/s

Leased lines – more topical than ever

Today, as most certainly in the future too, data are forwarded to modern communication nodes through fixed terrestrial networks. Leased lines are still the most efficient means of data transmission between the concentration points. In a state-of-the-art infrastructure, the classic leased line or one of its modern variants, like the logical leased line in *SDH** networks or a *PVC* or *S-PVC* in *ATM* networks, is often used to set up a permanent link with remote partners. The communication nodes of the

omnipresent Internet are also linked by this medium for instance. State-of-the-art communication networks are unimaginable without leased lines, which demonstrate their worth in numerous applications (see box on right).

A permanent link is more economical than a dial-up one if the traffic between two corporate sites exceeds a certain volume. If the partners communicate for more than 50 minutes per workday, a leased line is more attractive¹⁾, not to mention other factors like integrated data, speech and video, less time to set up calls and reliable availability.

* Abbreviations: see box on right.

FIG 2 Data encryption on leased lines with SITLink

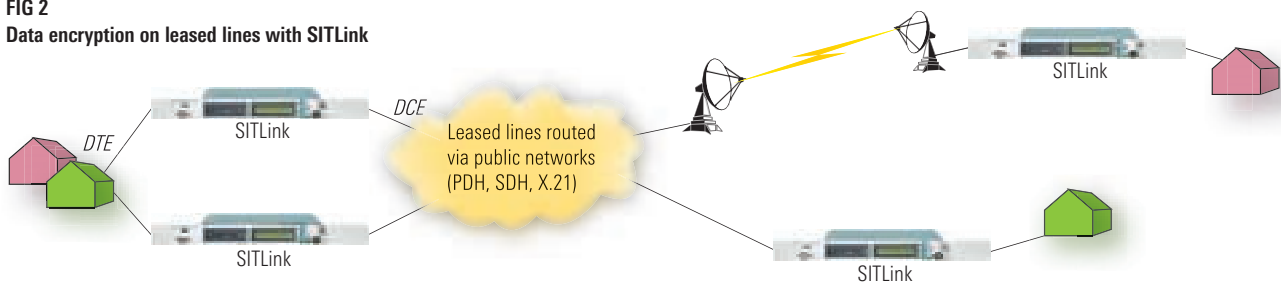

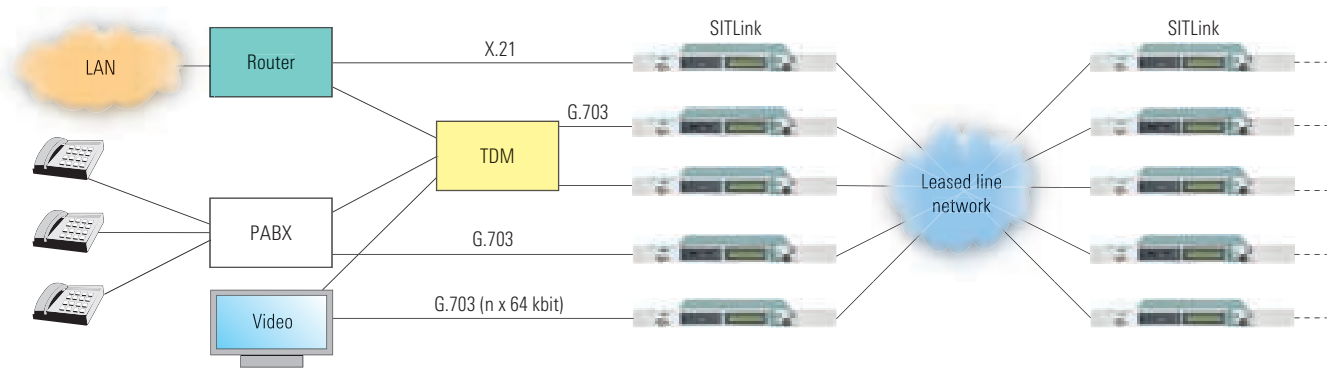

FIG 3 SITLink applications

Leased lines at risk too

As reliable and economical a permanent link may be, it is by no means resistant to attack. A leased line is usually installed on a continuous basis and through fixed routes. The user is normally unable to influence the media employed or the real route of the leased line once it is switched onto the public information highway. Contrary to public opinion, leased lines are not necessarily the shortest physical connection as even

satellite and microwave links may be involved. As can be imagined, an economical and reliable line does not really offer the best information security and confidentiality. These factors make the lines a target for espionage. The threat is often not taken very seriously, much to the delight of intruders.

SITLink ensures confidentiality

The powerful crypto algorithms of SITLink (FIG 1), a product of Rohde & Schwarz SIT GmbH, make eavesdropping on leased lines a fruitless enterprise. Even intentional or inadvertent misrouting is almost impossible and would not reveal any information to a chance recipient anyway. SITLink can be integrated into G.703 E1 lines and X.21 networks (FIGs 2 and 3).

Great emphasis was placed during design on making the system virtually invisible to the user. Neither quality nor bandwidth was to be degraded by the extra functionality. After installation, the system operates transparently for the user and largely unnoticed by the system. Operating and maintenance costs are significantly lower than with other solutions at protocol (e.g. IP) or even application (e.g. e-mail) level.

SITLink supports transmission rates up to 2 Mbit/s and encrypts data without restricting bandwidth. The short latency time of 0.5 μ s guarantees uniform link quality. Encryption is performed by the SCA95 crypto chip, a hardware tool that meets the most severe requirements.

A management system for the security functions permits secured access to

Abbreviations

<i>ATM</i>	Asynchronous transfer mode
<i>DCE</i>	Data circuit-terminating equipment
<i>DTE</i>	Data terminal equipment
<i>IP</i>	Internet protocol
<i>LSM</i>	Link security management
<i>PABX</i>	Private automatic branch exchange
<i>PDH</i>	Plesiochronous digital hierarchy
<i>PSTN</i>	Public switched telephone network
<i>PVC</i>	Permanent virtual circuit
<i>S-PVC</i>	Soft or signaled permanent virtual circuit
<i>SDH</i>	Synchronous digital hierarchy
<i>TDM</i>	Time division multiplex

Possible applications for leased lines

- Link-up of telephone and Internet and server-to-server link between headquarters and field office (small corporate networking); large corporate networking for many sites
- Simple LAN-to-LAN link
- Video telephony and video conferencing between corporate divisions and subsidiaries, Internet access of branch offices through the central gateway and firewall
- Link between corporations and production partners, call-up of inventory, placing of orders, access to databases
- Link between editorial office and printers for the transmission of print data, etc

FIG 4
PC-based *LSM* for management and monitoring of secured leased lines

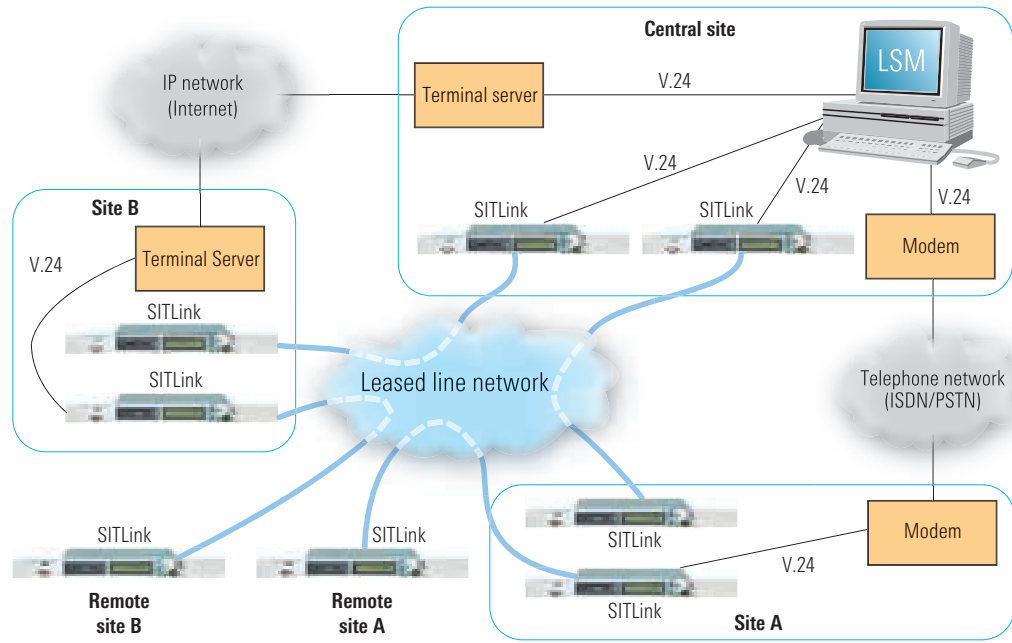

► the installed systems. In addition to cost-saving in-band access, the system can also be monitored via a separate network with greater fail-safety. Simple, PC-based *LSM* (FIG 4) provides scalable

solutions for monitoring and managing the security functions of a corporate network.

Ronald Kuhls

1) Cost analysis of Deutsche Telekom (see <http://www.telekom.de/angebot/datenkomm/nutzberater/index.htm>)

[Reader service card 169/11](#)

CD-ROM TIP | Broadcasting

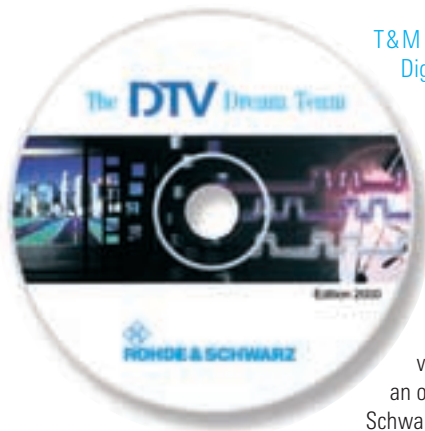

T&M Dream Team for Digital TV

The title of the new CD-ROM from Rohde & Schwarz sounds very promising. Behind it is the latest in test and measurement technology for digital television. The CD gives an overview of Rohde & Schwarz's wide product range for this market segment. The dream team mainly consists of generators and analyzers, pre-

sented through data sheets and detailed information material.

In addition, the CD contains demo versions of various test and analysis software tools. If you want, you can test whether they are up to your requirements in terms of operation and functionality. "Documentation" holds the entire operating manuals for the DTV equipment. Fields of application and practical use are described in numerous technical articles in pdf format.

And there is also a film on the silver disk if you want to know more about Rohde & Schwarz in general.

All in all, the CD-ROM is a recommendable compendium, available free of charge from your local Rohde & Schwarz representative (PD 757.4447.43).

Stefan Böttinger

Measuring noise figure on amplifiers in pulsed mode

To save power, amplifiers in TDMA mobile phones are only fed with current during the active slot. For this purpose, the bias voltage of the amplifier is usually applied in pulsed form, in the case of GSM for example with a pulse width of about 1/8 of the total 4.615 ms period. The noise figure, an important parameter also in power amplifiers, can only be determined with conventional measuring equipment if the amplifier is in a continuous mode, which may overload it and corrupt the result. Now there is a convenient way of determining the noise figure of amplifiers with a pulsed power supply: using Spectrum Analyzer FSP, Noise Measurement Software FS-K3 [1] and a function or pulse generator.

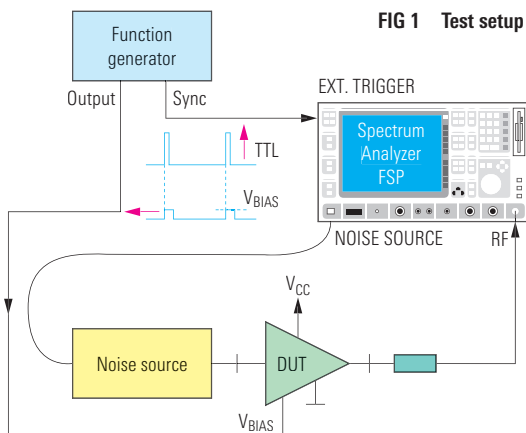

FIG 1 Test setup

Set an appropriate pulse signal on the function generator, in the case of GSM for example with pulse width of 577 μ s and pulse repetition period of 4.615 ms. You set the pulse amplitude according to the bias voltage of the amplifier under test. Connect the trigger or sync output of the function generator to the rear trigger input of FSP (FIG 1).

First preset FSP using the FS-K3 software ("Device" menu, FIG 2), and then change the following settings on FSP manually (in the example below for a GSM slot of 577 μ s width and 4.615 ms repetition period):

- TRIG:EXTERN: key
- Set the trigger offset so that the switching pulse (bias ON) barely appears on the screen
- MEAS key: TIME DOMAIN:SEARCH LIMITS ON. Set START LIMIT to the start of the pulse and STOP LIMIT to the end of it (FIG 3)



FIG 2 Setup of FSP with Noise Measurement Software FS-K3 (set sweep time set to 1 ms and average to 30 for example, deactivate "Init before measurement")

In this way you ensure that only the trace section representing the active amplifier phase will be evaluated on FSP. Further operation as well as graphical or tabular output of results with Noise Measurement Software FS-K3 are the same as in conventional measurements. This measurement is described in detail

- in an application note [2] that can be downloaded from the Rohde & Schwarz Internet pages.

Roland Minihold

REFERENCES

- [1] Noise Measurement Software FS-K3: Noise test system with FSE, FSIO or FSP analyzers. News from Rohde & Schwarz (2000) No. 167, p 23
 [2] Noise figure measurements on amplifiers in pulsed mode. Application Note 1MA32 from Rohde & Schwarz (home page: Products & More – Application Notes)

[Reader service card 169/12](#)

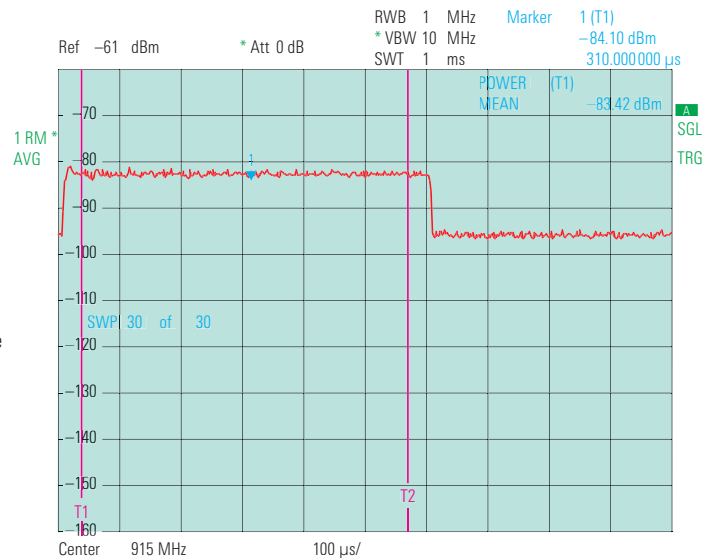

FIG 3 Selection of trace section to be evaluated on FSP by limit lines

Accurately measuring drift on Bluetooth™ transmitter modules

The Bluetooth* specifications [1, 2] contain a number of tests to be performed on transmitter modules. One of them is looked at here. This test tip explains how to measure frequency drift of Bluetooth transmitters very accurately, e. g. for module adjustment in equipment production. This test and others, which can be conveniently carried out with Spectrum Analyzers FSE and FSIO, are detailed in an application note.

Bluetooth uses time division duplex, i. e. with alternating transmit and receive bursts. This means that the synthesizer of a Bluetooth device continuously switches between transmit and receive frequencies and has to settle each time. Each burst carries a packet with control and useful data. Bluetooth uses frequency modulation and a Gaussian filter.

FIG 1 shows a Bluetooth burst recorded with Signal Analyzer FSIO. It does not show the amplitude of the burst, which extends practically over the whole screen, but instead the demodulated signal, i. e. frequency deviation versus time. You can see that the packet with valid modulation data starts relatively late in the burst. In the time before, the synthesizer settles to the particular transmit or receive frequency. The continuous trace is produced by linear interpolation between discrete samples. The specification stipulates four-fold oversampling, i. e. at least four samples per bit.

To find carrier frequency drift according to the Bluetooth RF test specification, you must compare the average frequency of the preamble (i. e. the first four bits of the packet) to the average frequencies of 10-bit sections of the payload data field.

In this measurement, zeros and ones alternate as modulation data in the preamble and the payload. The Bluetooth signals are frequency-modulated, so you obtain the average frequency

of a section carrying equal numbers of zeroes and ones by adding up all samples of this section and dividing by the number of samples.

If this rule is applied to the four bits of the preamble however, a significant systematic error results for most Bluetooth transmitters. This is because the logic level of the first bit of the preamble, i.e. the first valid bit of the packet, is usually already present some time before the packet starts (FIG 1a). In this case the logic level is zero, so the sum of the samples of the first bit of the preamble is clearly more negative than that for the third bit for example. This is demonstrated in detail by FIG 2.

If precise adjustment of the preamble frequency is required, e.g. in equipment production, the error described can be quite simply avoided by using only the samples of the middle or the last two preamble bits to calculate the average frequency.

You find the same systematic error if several ones appear immediately before the payload data field (FIG 1b). Here the sum of the samples for the first bit is too positive. To obtain a correct result, you must ignore the first pair of bits.

In addition, in those regions without a bit change, the frequency deviation is always larger since here the modulation filter has fully settled. This aggravates the error observed above. By intentionally leaving out the boundary bits in sample evaluation, the preamble frequency and maximum drift can be measured with much greater accuracy – more than a factor of ten.

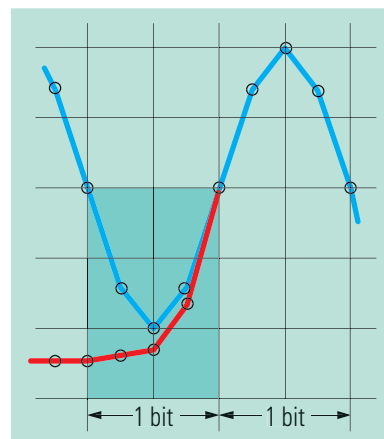

FIG 2 Samples with (blue) and without (red) bit change

In the case of the preamble frequency for example, this means an error of less than 500 Hz compared to as much as 10 kHz when measuring to the Bluetooth standard.

FIG 1 Demodulated Bluetooth signal

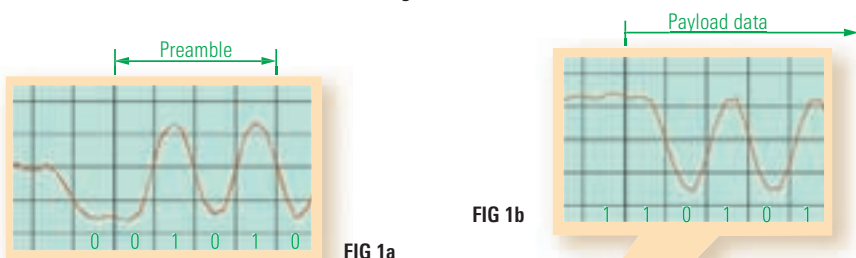
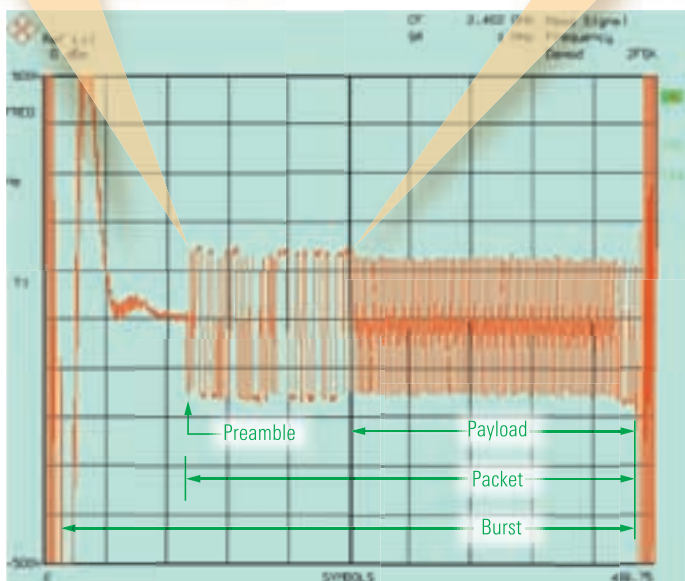

FIG 1a

FIG 1b

The above procedure is described in detail in an application note [3]. The methods discussed are already implemented in the accompanying demo program.

Detlev Liebl



REFERENCES

- [1] Bluetooth RF Test Specification, Revision 0.9, 14.3.2000
- [2] Bluetooth Core Specification, Revision 1.0b, 12.6.1999
- [3] Transmitter measurements on Bluetooth modules. Application Note 1MA26 from Rohde & Schwarz (home page: Products & More – Application Notes – Bluetooth – 1MA26)

* Bluetooth is a registered trademark of Telefonaktiebolaget LM Ericsson Sweden and is licensed to Rohde & Schwarz.

HTML online help

Expert knowledge available at a mouse click

Modern measuring equipment and application programs have numerous functions – and the volume of user documentation increases with product complexity. With the number of pages in a manual, the time spent finding what you are looking for increases, too. HTML online help with its automatic search and navigation tools offers ideal support.

HTML: standard for virtually every platform

The current tools for generating help systems based on HTML¹⁾ provide two different versions of this format: compiled and non-compiled.

Non-compiled HTML documentation comprises various text and graphics files that can be displayed with any browser. Clearly structured and featuring convenient navigation aids, it can be displayed on the measuring instrument or on a PC running under different operating systems. The platform independence of the HTML format is used by Rohde & Schwarz for the extensive documentation of Bluetooth™ Protocol Tester PTW60²⁾ (FIG 1) for example.

Compiled HTML documentation is ideal for the wide range of applications and

instruments running on a version of the Windows™ operating system. All text and graphics files along with a wealth of other structure information are organized and compressed in a single file (see example on right). Context-sensitive implementation of this help is simple. The topic corresponding to any control element of the application appears at a mouse click.

Choosing the form and design of the HTML help depends on the desired functionality and system requirements. A suitable solution exists for virtually any application. This flexibility is the main argument in favour of using HTML help in applications and measuring equipment from Rohde & Schwarz.

One source – many uses

HTML documents are developed at Rohde & Schwarz parallel or as an alternative to the printed manual. With state-of-the-art conversion programs and editors, it is possible to generate various output formats from a single source, e. g. for electronic or print media. The different media must be considered in the conception of the documentation but the reward is cost-effective generation and simpler updating.

Dr Martin Jetter

FIG 1
Platform-independent – the non-compiled HTML help for Bluetooth™ Protocol Tester PTW60 can be displayed with any browser

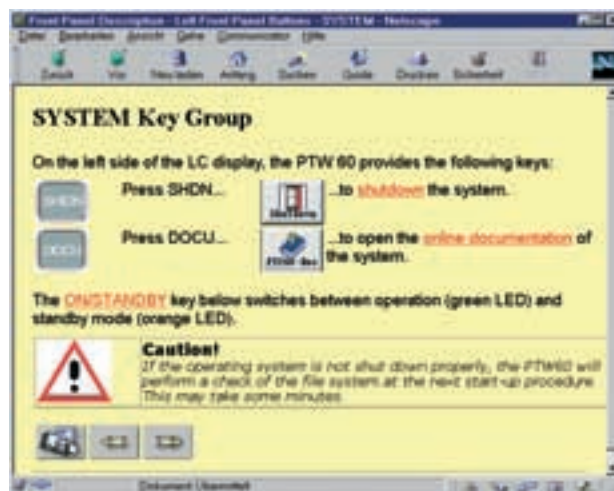

- 1) HTML: hypertext markup language, standard for displaying contents in the World Wide Web
- 2) See page 8.

Example: HTML documentation for Universal Radio Communication Tester CMU

Universal Radio Communication Tester CMU is an example of a product where integration of help functions into the firmware is not of primary importance. The versatility of this advanced multi-standard tester requires detailed and extensive user documentation. CMU was essentially developed for use in production, so information related to programming and remote control is particularly important. Furthermore, the instrument will mostly be operated from an external controller. For these reasons, an HTML help system running under Windows™ and independent of the instrument is offered in addition to the printed manual.

Users wanting information on a specific measurement or device function have a variety of search and navigation tools at their disposal: automatic list of contents, index and full-text search. Hyperlinks associate help topics with related content and explanations of specific terms appear in popup windows (FIG 2).

Programmers looking for a function's remote-control command will find the exact syntax at the end of the function description. A click on the command and the user can view the tabular description, which contains the syntax and list of admissible parameters, the range of values for each numeric parameter as well as the default setting and a short description (FIG 3). Alternatively, each command is indicated in the automatic index or can be called using the name of the corresponding device function. There is no need any more to type commands for instrument programming because they can be extracted from the help by copying them into the clipboard. Application engineers in the field benefit especially from HTML help: they no longer have to carry weighty manuals along with them.

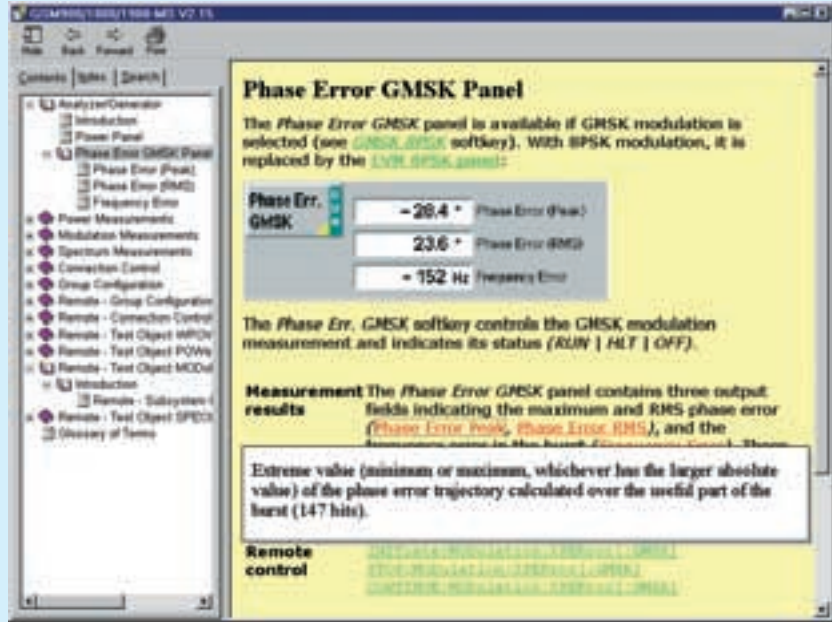

FIG 2 Detailed explanation of all device functions – popup windows tell you the specifics

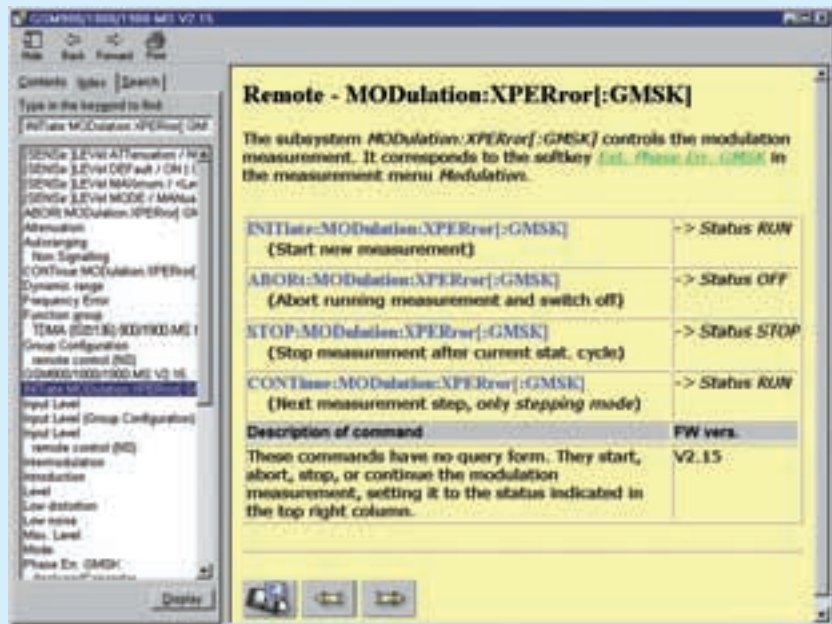
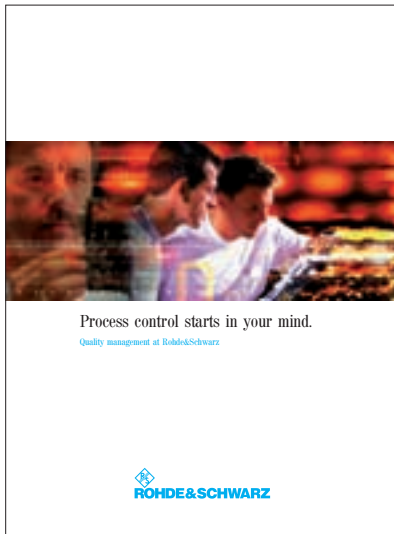

FIG 3 Syntax for a remote-control command is found in next to no time



Process control starts in your mind: Quality management at Rohde & Schwarz Quality is not only the result of careful product planning, development and production, but also depends on the attitude of every employee and the strict compliance with defined quality management processes. The brochure shows what Rohde & Schwarz does to guarantee the quality of its products and services.

Brochure PD 757.6127.21 enter 169/14

GSM/GPRS Interference Analyzer ROGER (TS9958) Test system for full-coverage, mobile and automatic detection of GSM interference. ROGER can optionally be fitted with a position trigger so that it can also carry out classic coverage measurements (News from Rohde & Schwarz No. 168 (2000), p 4–6).

Data sheet PD 757.6079.21 enter 169/15

Production Test Platform TSVP Platform for adaptation and electrical testing of modules and terminals in production (see p 6).

Data sheet PD 757.6291.21 enter 169/16

SITLink: secure communication on leased lines SITLink enables encrypted communication on leased lines up to 2 Mbit/s. The unit is suitable for remote maintenance and can be used in various infrastructures (see p 36).

Data sheet PD 757.6027.22 enter 169/17

SITCard-S: PC card for file encryption SIT-Card-S consists of a user interface and a hardware module for file encryption in the form of a PC card. Typical applications are e.g. protection of files on the hard disk of a PC against access by intruders, protection of data transmitted on insecure networks (Internet, telephone line/modem).

Data sheet PD 757.6362.21 enter 169/18

SITMinisafe: encryption of modem links SIT-Minisafe is an external device for encrypting data transmitted via modems. It is connected between the COM ports of the PC and the modem. The data are automatically encrypted before transmission and then decrypted at the receive end where another SITMinisafe is installed.

Data sheet PD 757.6279.21 enter 169/19

EMC test antennas for applications from 5 Hz to 26.5 GHz Overview of all Rohde & Schwarz antennas for this field of application.

Data sheet PD 757.5743.21 enter 169/20

The World of Radio Communications 2000/2001 The catalog has been translated into Spanish, except for the specifications and chapter 5 "Typical system configurations". These sections – in English – are however included on the accompanying CD-ROM PD 757.5266.21.

Catalog PD 757.1977.44 enter 169/21

Protocol Tester for Bluetooth™ Solutions PTW60 The world's first protocol tester for Bluetooth networks.

Data sheet PD 757.5720.21 enter 169/22

Competence in microwaves This brochure describes on 44 pages the complete product range of Rohde & Schwarz for microwave measurements, informs about microwave antennas and presents the microwave history at Rohde & Schwarz.

Brochure PD 757.6162.21 enter 169/23

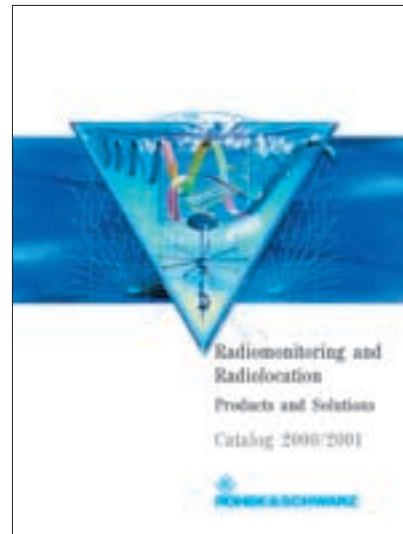

Radiomonitoring and Radiolocation Products and Solutions Catalog 2000/2001, including CD-ROM For the first time Rohde & Schwarz has published a complete catalog on radiomonitoring and radiolocation. The reader will find everything from antennas, receivers, direction finders and analyzers through to turnkey monitoring systems. The catalog also gives an overview of formulae for antennas as well as an introduction into the theory of direction finding. It is of course also available as a CD-ROM.

Catalog PD 757.5937.21 enter 169/24
CD-ROM PD 757.5972.21 enter 169/25

Signal Generator SML The new economy models SML02 and SML03 master the frequency range up to 3.3 GHz.

Data sheet PD 757.5550.22 enter 169/26

Vector Network Analyzers ZVM, ZVK The new ZVK extends the frequency range of the analyzer family to 40 GHz.

Data sheet PD 757.5543.21 enter 169/27

It's never too early to start in the right direction! Our program for students. The brochure informs about the opportunities that Rohde & Schwarz offers to students: practical training, dissertations and programs for working students.

Brochure PD 757.6104.21 enter 169/28

Why choose a career at Rohde & Schwarz? Five answers to a good question. The brochure addresses students who are about to graduate. It shows on 20 pages why Rohde & Schwarz is an attractive employer for young people.

Brochure PD 757.5895.21 enter 169/29



Powerful tester

Universal Radio Communication Tester CMU200 was in the focus and on the title spread of the annual T&M review by the German Design & Elektronik magazine. In the editorial "Tested Mobility", it said:

"None of the big names could afford to let any appreciable number of mobile phones with defects to reach the market. It would seriously damage the producer's reputation, given the widespread popularity of these phones. That is why every single one is usually tested. The Rohde & Schwarz product range includes a very powerful test system for 2G mobile phones."

Handheld tester for telecom

The cover of the September issue of Germany's ntz sported the handheld tester Victoria, which is marketed through Rohde & Schwarz Engineering and Sales (RSE). In the magazine you could read about the capabilities of this device, under the appropriate title "David overcomes Goliath":

"Miniaturization is making testers for the installation and maintenance of telecom systems not only smaller and more manageable but also more powerful and easier to operate. ...The new Victor and Victoria family of testers from Rohde & Schwarz offers a surprisingly large functionality, in fact you would only have expected it to date from a larger instrument with PC-controlled menu guidance."

Modern dual-use technology

"Military and commercial technologies merge" – under this title the June issue of Electronics Designer reported on the latest developments in communications engineering. The magazine's cover showed the multiband/multimode/multirole M3TR software radio from Rohde & Schwarz.



The honeymoon is over

A front-page headline of Tanzania's Daily News, published in Dar es Salaam, reported on 22 August 2000 about a spectrum monitoring system from Rohde & Schwarz that had been purchased by the national communications administration:

"The honeymoon is over for frequency pirates following the acquisition of a mobile frequency monitoring unit by the Tanzania Communications Commission (TCC) in Dar es Salaam yesterday. The state-of-the-art equipment, valued at 400 000 US dollars, was handed over to the Director-General of TCC, Col. Abihudi Nalingigwa, by representatives of German suppliers Rohde & Schwarz."

Stefan Böttinger

Rohde & Schwarz opens broadcast engineering office in Miami

Worldwide expansion of analog and now digital television

technologies is gathering pace. And here the Latin-American market is growing in significance. For this region, including Central America and the Carib-

bean, Rohde & Schwarz has consequently set up an office in Miami, Florida, especially for sales and support of broadcast technology. On-the-spot support

can be offered from here within a few hours in any city of Central and South America.



▶ **Video Quality Analyzer DVQ wins an EMMY**
Rohde & Schwarz's Video Quality Analyzer DVQ won the EMMY of the US National Academy of Television Arts and Sciences (photo below). DVQ won the award in the category "advanced picture quality measurement technology for digital TV" because of the revolutionary way in which it determines picture quality without the use of a reference signal. The award, the most prestigious prize in the television world, is presented annually in New York for outstanding technical achievements.

The analyzer both measures and monitors the quality of the picture in digital TV broadcasts in realtime and without a reference signal. To do this, it automatically examines the live digital images for artifacts and disturbance and evaluates them just as they are perceived by a human viewer. In this way, despite an increasing amount of digital TV programs, providers are able to ensure their audi-

ences high-quality pictures. For the measurement principle used by the video quality analyzer and developed in cooperation with Rohde & Schwarz, an EMMY also went to the Institute of Telecommunications Engineering of Braunschweig University.

German Armed Forces to phone encrypted
Rohde & Schwarz SIT, a subsidiary of Rohde & Schwarz, has won an order from the German Armed Forces to supply 1500 ISDN crypto telephones of the type ELCRODAT 6-1. All command posts will be equipped with them by mid-2001 so that they can communicate securely. The units are being produced in a high-security wing of the Memmingen plant. There, at the end of September, the first of these telephones was handed over to a German Armed Forces representative (photo above).



Henning Krieghoff of SIT (right) handing over the first ISDN crypto telephone to director Franz-Josef Ganz



ELCRODAT 6-1, which can work in both a normal and a cipher mode, automatically encrypts ISDN voice connections and also allows encrypted transmission of data. The user must first authenticate with a chip card and PIN code, codes being distributed by a crypto management system. The phones are authorized for confidential and secret military classification levels, so they may be used for calls concerning official secrets or to transmit data of the same nature.

Stefan Böttinger

Modern T&M at electronica 2000

At the electronica, staged in Munich from 21 through 24 November 2000, Rohde & Schwarz's exhibits included the world's first RF and signaling tester for Bluetooth™, a GSM base station tester plus NetHawk™ products for analysis and simulation on common interfaces of modern transmission technologies. For the upper microwave region, the company presented signal generators plus spectrum and network analyzers.

In addition to GSM, mobile-radio tester CMU 200 now comes with test software for American standards AMPS and TDMA as well as CDMA. Based on the CMU platform, Rohde & Schwarz was able to present the world's first unit for full RF and signaling tests of Bluetooth™ components. CMU 300 was developed especially for requirements in the production of mobile-radio base stations. A flexible platform, this tester – like CMU 200 – is available for all GSM standards and already features 8PSK (EDGE) capability.



Obviously very pleased with their EMMY (from right): Markus Trauberg (telecommunications engineering faculty of Braunschweig University), Friedrich Schwarz (President and CEO of Rohde & Schwarz) and Harald Ibl (head of R&D for TV baseband test and measurement products)

NetHawk™ products are plug-ins for PCs and software for analysis and simulation on common interfaces of modern transmission systems and telecommunication networks.

The ZVR family of network analyzers has expanded, with a new model ZVK that takes the frequency range up to 40 GHz. The instrument features a wide dynamic range and enhanced measuring speed. The spectrum analyzers of the FSP family now also work into the microwave region. The new units are thus suitable for measurements in microwave and radar applications. Signal Generator SMR, which also ranges up to 40 GHz, can work as a pulse-modulated CW source, an AM/FM generator and as a synthesized sweeper with fast analog ramp sweep.

Transmitter for Australia's PRIME TV
A 30 kW transmitter of the new, liquid-cooled generation (photo bottom left) was ordered by PRIME TV from Rohde & Schwarz Australia. PRIME TV, one of the country's biggest commercial broadcasters, intends to use the transmitter for its new UHF service in Mawson Trig, Western Australia.

Thanks to an innovative cooling concept, the floor print of the rack is reduced by more than half in the new transmitter generation. This was one of the reasons why PRIME TV opted for Rohde & Schwarz as its supplier. Fast delivery, the high availability and efficiency of the system plus simple conversion from PAL to DVB-T also played a role. This future-proof design means that high-performance TV transmitter networks can be set up and operated today and still used tomorrow for new broadcast technologies like DVB.

Through this first contract, Rohde & Schwarz's modern DVB broadcast technology, which already leads the European market, has now set foot down under. Local support came from the newly established Broadcast Group in Sydney.

Lou Cossetto

TETRA mobile-radio network in Greater Vienna goes on the air with Rohde & Schwarz
Rohde & Schwarz BICK Mobilfunk won a contract from TetraCall in Vienna, which erects and operates trunked-radio networks, to supply an ACCESSNET®-T mobile-radio network. It consists of 62 TETRA base stations plus a TETRA and a fixed-network switching center. TetraCall is a joint initiative between the Vienna Municipal Works,

Siemens Austria and other Austrian corporations.

With its 62 base stations, TetraCall will be able to cover all of Greater Vienna. Six stations will already provide coverage for large parts of the city and the airport in November 2000. The final configuration of the network is due for completion by the end of 2001.

Radiocommunication with tactical Internet in Swedish Armed Forces

Sweden's Armed Forces are using the multiband / multi-mode / multirole M3TR radio from Rohde & Schwarz in a test environment to develop tactical Internet as part of tactical radiocommunication. The reasons for choosing this Rohde & Schwarz unit were its availability, its design as a software radio with COMSEC/TRANSEC, its TCP/IP capability plus its high data rate of 64 kbit/s.

With the test system, the Swedish Procurement Agency FMV intends to create a tactical radiocommunication environment in

Photo 43392/1



Photo author

EMC test system for China National R. M. C.
The Rohde & Schwarz Support Center Asia (SCA) was awarded a two million DM contract for delivery of an EMC test system to the China National Radio Monitoring Corporation (R. M. C.). The contract was officially signed at a ceremony in the West Garden Hotel in Beijing (photo above). The EMC test system enables numerous technical items, like terminals, mobile phones, industrial and other commercial equipment, to be examined for susceptibility to interference. The system is destined for one of the country's biggest EMC test centers.

Joseph Soo

which both voice communication and data transmission, tactical Internet and the networking of different subsystems are implemented and can be introduced step by step. The tests are the preparation for the major procurement phase in the first half of 2002, when part of the Swedish Armed Forces at battalion level is to be equipped with the new technology.

Stefan Böttinger

Visit us on Internet at www.rohde-schwarz.com



ROHDE & SCHWARZ

ROHDE & SCHWARZ GmbH & Co. KG · Mühldorfstrasse 15 · 81671 München, Germany · P.O.B. 80 14 69 · 81614 München
Support Center: Tel. (+49) 018 05 12 42 42 · E-Mail: customersupport@rohde-schwarz.com · Fax (+49 89) 41 29-137 77